

A Constraint-based Semantics for Tenses and Temporal Auxiliaries

FRANK VAN EYNDE

13.1 Introduction

Combining ideas from Donald Davidson, Hans Reichenbach and Discourse Representation Theory (DRT), I will develop a constraint-based semantics for the Dutch tenses and temporal auxiliaries which is fully integrated in the HPSG framework. The semantics will be inspired to a large extent by DRT, but the syntax is squarely based on the lexicalist surface-oriented approach of HPSG, and so is the treatment of the relation between syntax and semantics. Instead of DRT's construction rules which map syntactic structures onto discourse representation structures, I will use lexically anchored constraints on the relation between syntactic, semantic and pragmatic properties of signs. Since the constraints which I will use are monotonic, the resulting treatment is non-directional, in contrast to DRT's construction rules, which are unidirectional (from syntax to semantics) and irreversible. Next to this technical advantage, there is also a conceptual one: since the construction rules of DRT have the unlimited power which was once characteristic of transformations in the Standard Theory, they allow for such a broad range of stipulations and arbitrarily complex conditions that the linguist is not encouraged to strive for maximum transparency in the formulation of relations between syntax and semantics/pragmatics. The constraint-based approach, on the other hand, imposes a much tighter discipline on the formulation of such relations, and thus enhances the possibility of arriving at computationally viable analyses.

The paper starts with a section on the representation of tensed verbs in general, and then covers the Dutch tenses, the auxiliaries of the perfect

Grammatical Interfaces in HPSG.
Ronnie Cann, Claire Grover and Philip Miller.
Copyright © 2000, Stanford University.

(*hebben* and *zijn*) and the auxiliary of the future (*zullen*).

13.2 The Semantic Representation of Tensed Verbs

Most versions of the Predicate Calculus (PC) use only one type of variables, as in the following representation of *John bought a horse*.

$$(1) \quad \exists x [\text{horse}(x) \ \& \ \text{bought}(j,x)]$$

This style of analysis has been challenged by Donald Davidson. In Davidson (1967) he argued for the use of event variables in the analysis of action sentences, as in

$$(2) \quad \exists x \exists e [\text{horse}(x) \ \& \ \text{bought}(e,j,x)]$$

This notation is somewhat more verbose and assumes a richer ontology than standard PC, but it facilitates the treatment of VP modification. The modifier in *John bought a horse in Egypt*, for instance, is a constraint on the location of the buying event, and not on the location of either John or the horse. The first argument of *in* should, hence, be identified with the event of buying, as in

$$(3) \quad \exists x [\text{horse}(x) \ \& \ \text{in}(\text{bought}(j,x),\text{egypt})]$$

While brief and plausible, this representation is less appropriate for modelling inferences; the fact, for instance, that *John bought a horse in Egypt* necessarily implies that *John bought a horse* would require a separate statement. By contrast, in the notation with an event variable, this simply follows from the logic of conjunction ($p \ \& \ q \rightarrow p$).

$$(4) \quad \exists x \exists e [\text{horse}(x) \ \& \ \text{bought}(e,j,x) \ \& \ \text{in}(e,\text{egypt})]$$

Another argument for the use of event variables concerns the fact that natural languages allow for quantification over events and for pronominal reference to events, as in

$$(5) \quad \text{Whenever it rains, John sneezes.}$$

$$(6) \quad \text{Mary is going out with George. Bill does not like it.}$$

For a good survey of the major arguments in favor of the event type analysis, see (Parsons, 1990, 13-19) and (Kamp and Reyle, 1993, 504–10).

In HPSG, where the PC variables roughly correspond to indices, it is standard practice to limit the use of indices to the representation of nominal projections, see Pollard and Sag (1994). For a variety of reasons, however, many authors have argued for a wider use of indices and also employ them for the representation of verbal projections, see

a.o. Sanfilippo (1990), Van Eynde (1998) and Sag and Wasow (1999).

Adopting this Davidsonian style, the CONTENT values of verbal signs can be given the same general format as the ones of nominal signs.

$$(7) \left[\begin{array}{l} \text{CATEGORY} \mid \text{HEAD} \quad \textit{noun} \\ \text{ARG-ST} \quad \langle \rangle \\ \text{CONTENT} \quad \left[\begin{array}{l} \text{INDEX} \quad \boxed{1} \text{ ref} \\ \text{RESTR} \quad \left\{ \textit{horse} \left[\text{INST} \quad \boxed{1} \right] \right\} \end{array} \right] \end{array} \right]$$

$$(8) \left[\begin{array}{l} \text{CATEGORY} \mid \text{HEAD} \quad \textit{verb} \\ \text{ARG-ST} \quad \langle \text{NP}_{\boxed{1}}, \text{NP}_{\boxed{2}} \rangle \\ \text{CONTENT} \quad \left[\begin{array}{l} \text{INDEX} \quad \boxed{3} \text{ ref} \\ \text{RESTR} \quad \left\{ \begin{array}{l} \text{INST} \quad \boxed{3} \\ \text{BUYER} \quad \boxed{1} \text{ ref} \\ \text{BOUGHT} \quad \boxed{2} \text{ ref} \end{array} \right\} \right] \end{array} \right]$$

In both cases there is a referential index which is further constrained by at least one restriction.

The introduction of verbal indices also facilitates the analysis of the tenses. The temporal meaning of a past tense verb, for instance, could be analyzed as a precedence relation between its index and the time of utterance. While basically sound, many authors have argued that this relation is somewhat more complex. Reichenbach (1947), for instance, claimed that the relation between events and utterance times should be mediated by event and reference times, and similar claims can be found throughout the vast literature on tense and aspect, see Binnick (1991) for a good survey. Also in Pollard and Sag (1994) it is clearly suggested—in a footnote—that the semantic analysis of tense requires more than events and utterance times: “. . . we assume that the proper way to handle it [= tense, FVE] is in terms of an additional LOCATION role in the CONTENT value together with certain *context* attributes concerning temporal location, corresponding (say) to Reichenbach’s utterance time, reference time, and event time. For example, present tense might be treated by structure sharing the EVENT-TIME value in the CONTEXT with the index of the LOCATION value in the CONTENT, and adding a BACKGROUND psoa [= parametrized-state-of-affairs, FVE] restricting the EVENT-TIME value to temporally overlap the UTTERANCE-TIME value.” (o.c., 29) Following this suggestion, the present tense forms of *buy* can

be analyzed as follows.

$$(9) \left[\begin{array}{l} \text{CATEGORY} \mid \text{HEAD } \textit{verb} \\ \text{CONTENT} \left[\begin{array}{l} \text{INDEX } \boxed{1} \text{ ref} \\ \text{RESTR } \left\{ \begin{array}{l} \left[\begin{array}{l} \text{INST } \boxed{1} \\ \text{BUYER } \text{ref} \\ \text{BOUGHT } \text{ref} \end{array} \right] \textit{buy} \left[\begin{array}{l} \text{INST } \boxed{1} \\ \text{LOC } \boxed{2} \end{array} \right] \end{array} \right. \\ \text{CONTEXT} \left[\begin{array}{l} \text{C-INDICES } \left[\begin{array}{l} \text{EVENT-TIME } \boxed{2} \text{ temp} \\ \text{REF-TIME } \text{temp} \\ \text{UTT-TIME } \boxed{3} \text{ temp} \end{array} \right] \\ \text{BACKGROUND } \{ \boxed{2} \circ \boxed{3} \} \end{array} \right] \end{array} \right] \end{array} \right]$$

The verbal index $\boxed{1}$ is related to a location $\boxed{2}$, which is an object of type *temporal* and which is introduced in the *CONTEXT* attribute, more specifically as the value of *EVENT-TIME*.¹ Though sketchy, this format provides a useful starting point for a constraint-based analysis of the Dutch tenses and temporal auxiliaries.

13.3 The Dutch Tenses

Like English, Dutch has two tenses: the present and the past. For their analysis I will combine insights from the Reichenbachian tradition with some more recent developments in Discourse Representation Theory (DRT), as described in Kamp and Reyle (1993).

13.3.1 The Past Tense

In contrast to Reichenbach (1947), who provides a uniform analysis of the simple past ($E = R$, $R < S$), DRT emphasizes that its interpretation in event describing sentences is fundamentally different from its interpretation in state describing sentences. Compare

(10) John bought a horse yesterday.

(11) Bart was ill yesterday.

The first sentence is only true if the buying event is temporally included in yesterday, whereas the second sentence is also true if Bart's illness extends beyond yesterday: it may have started earlier and it may

¹The *LOCATION* attribute could also be treated as an extra-role in the *buy*-predicate itself, but the advantage of the present—more modular—structure is that it enables us to refer to the temporal properties of the predicate, without having to mention its other semantic roles.

go on after yesterday. In order to capture this difference DRT stipulates that the relation between the described situation and the time of utterance is mediated by a time of location. More specifically, if a past tense sentence describes an event (e), then the event is included in a time of location (t) which precedes the time of utterance ($e \subseteq t$ and $t < u$), and if it describes a state (s), then the state overlaps a time of location (t) which precedes the time of utterance ($s \circ t$ and $t < u$). As is clear from this formulation, the location time of DRT does not stand for the temporal location of the situation itself, but rather for a time with respect to which the situation's location is defined. In Reichenbach's terms, it would be more like the reference time than like the event time.

The distinction between states and events is also relevant for the analysis of the Dutch past. More specifically, the observations about the difference between *bought* and *was* also apply to their Dutch equivalents.

(12) Jan kocht gisteren een paard.
 John buy.PAST yesterday a horse
 'John bought a horse yesterday.'

(13) Bart was gisteren ziek.
 Bart be.PAST yesterday ill
 'Bart was ill yesterday.'

In order to model this in the constraint-based style of HPSG I will make use of three implicational constraints. The most general one (IC-VERB) applies to all substantive verbal signs, both lexical and phrasal ones.²

$$\text{subst} \left[\text{CAT} \mid \text{HEAD} \quad \text{verb} \right] \rightarrow \left[\begin{array}{l} \text{CONT} \left[\begin{array}{l} \text{INDEX} \quad \boxed{1} \text{ ref} \\ \text{RESTR} \quad \left\{ \begin{array}{l} \text{INST} \quad \boxed{1} \\ \text{LOC} \quad \boxed{2} \end{array} \right\} \right. \\ \left. \text{at} \left[\text{LOC} \quad \boxed{2} \right] \right\} \end{array} \right] \\ \text{CONX} \left[\begin{array}{l} \text{C-INDS} \left[\begin{array}{l} \text{SIT-TIME} \quad \boxed{2} \text{ temp} \\ \text{LOC-TIME} \quad \boxed{3} \text{ temp} \end{array} \right] \\ \text{BACKGROUND} \quad \left\{ \boxed{2} \circ \boxed{3} \right\} \end{array} \right] \end{array} \right]$$

In words, every substantive verbal sign has a referential index which is related to a temporal location, more specifically its situation time,³

²The relevance of the restriction to substantive signs will become apparent in the section on the past time perfect.

³The situation time is comparable to Reichenbach's event time. I prefer the term *situation* since it generalizes over states, events and other types of actions.

and the latter is required to overlap the time of location.

The second constraint (IC-PAST) applies to the substantive past tense verbs.⁴

$$subst \left[\begin{array}{l} \text{CAT} \mid \text{HEAD} \mid \text{VFORM} \\ \text{past} \end{array} \right] \rightarrow \left[\begin{array}{l} \text{C-INDS} \left[\begin{array}{l} \text{LOC-TIME} \quad \boxed{1} \text{ temp} \\ \text{UTT-TIME} \quad \boxed{2} \text{ temp} \end{array} \right] \\ \text{BACKGROUND} \quad \{ \boxed{1} < \boxed{2} \} \end{array} \right]$$

The third constraint (IC-EVENT) only applies to event describing predicates, adding the requirement that the event's location be included in the time of location. To model this I start from the assumption that the main distinguishing characteristic of event type predicates is that they present a situation as bounded in time.⁵ The temporal extension of a predicate like *wrote this letter*, for instance, is bounded, since writing this letter takes a specifiable amount of time: once the letter is finished, the event is over. By contrast, the temporal extension of *wrote letters* is unbounded, since the action can go on indefinitely: there is no built-in termination point. A well-known test for drawing this distinction is based on the form which the durational adjunct takes: if the predication's location is unbounded, the adjunct is introduced by *for*, and if it is bounded, the adjunct is introduced by *in*, cf. *wrote letters for/*in the whole afternoon* vs. *wrote this letter in/*for half an hour*. Since the bounded/unbounded dichotomy applies to temporal objects, it seems natural to associate it with the objects of type *temporal*.

$$(14) \quad temp \left[\begin{array}{l} \text{BOUNDED} \\ \text{boolean} \end{array} \right]$$

In the lexicon, the LOC value of most verbs is the underspecified *boolean*, since they can just as well head a bounded VP as an unbounded one. It is only after the addition of the complements and/or adjuncts that *boolean* can be replaced with a more specific value, cf. the bounded

⁴In DRT, the relation between the location time and the time of utterance is mediated by a temporal point of perspective. The relevance of this extension, though, is limited to the analysis of some rather marked discourse phenomena, such as flashbacks, free indirect speech and inner monologues. For the purpose of this paper, I will make the simplifying assumption that the point of perspective coincides with the time of utterance. For an analysis which also covers contexts in which the perspective time is dissociated from the utterance time, see Van Eynde (1998).

⁵The familiar distinction between telic and atelic predicates is a special case of this: telic predicates have a built-in termination point and are hence bounded at the end, whereas atelic predicates lack such a point and are hence unbounded at the end.

wrote *this letter* vs. the unbounded *wrote letters*. For a detailed formal account of how this can be done in a compositional way, see Verkuyl (1993). Assuming that this can also be modeled in terms of a lexicalist framework as HPSG, and admitting that this still needs to be worked out, we can formulate IC-EVENT as follows.

$$\begin{array}{l}
 \left[\begin{array}{l}
 \text{CATEGORY} \left[\begin{array}{l} \text{HEAD} \textit{verb} \\ \text{COMPS} \langle \rangle \end{array} \right] \\
 \text{CONTENT} \left[\begin{array}{l}
 \text{INDEX} \boxed{1} \textit{ref} \\
 \text{RESTR} \left\{ \begin{array}{l}
 \left[\begin{array}{l} \text{INST} \boxed{1} \\ \text{LOC} \boxed{2} \textit{temp} \left[\text{BOUNDED} + \right] \end{array} \right] \\
 \left[\textit{at} \right]
 \end{array} \right\}
 \end{array} \right]
 \end{array} \right] \\
 \textit{subst}
 \end{array}
 \right.
 \end{array}
 \rightarrow
 \left[\begin{array}{l}
 \text{CONTEXT} \left[\begin{array}{l}
 \text{C-INDS} \left[\begin{array}{l} \text{SIT-TIME} \boxed{2} \\ \text{LOC-TIME} \boxed{3} \textit{temp} \end{array} \right] \\
 \text{BACKGROUND} \left\{ \boxed{2} \subseteq \boxed{3} \right\}
 \end{array} \right]
 \end{array} \right]
 \end{array}$$

In words, if a verbal sign with an empty COMPS list has a bounded temporal location, then the latter is included in the time of location. Since inclusion is a special case of overlap, this constraint does not contradict the more general IC-VERB; it only provides more specific information.

An interesting property of this analysis is that it correctly predicts the contrast in

- (15) Bart was gisteren al een week ziek.
 Bart be.PAST yesterday already a week ill
 ‘Bart had been ill for a week yesterday.’
- (16) ? Laura schreef gisteren een sonnet in een week.
 Laura write.PAST yesterday a sonnet in a week

The state describing sentence is well-formed, since a state is only required to overlap the time of location, so that its temporal extension (a week) may exceed the one of the time of location (yesterday). The event describing sentence, on the other hand, is not well-formed, since an event is required to be included in the time of location.

This greater flexibility in the interpretation of temporally unbounded predications does not mean that they cannot be constrained in other

ways. In the following sentence, for instance, Bart's stay in Brussels is not meant to overlap with yesterday, but rather to be included in it.

- (17) Bart was twee uur in Brussel gisteren.
 Bart be.PAST two hour in Brussels yesterday
 'Bart was in Brussels for two hours yesterday.'

This more specific interpretation is due to the semantic contributions of the temporal adjuncts. For a proposal on how this can be modelled in the present framework, see Schelkens et al. (2000).

13.3.2 The Present Tense

Semantically, the Dutch present is complementary to the Dutch past. Whereas the latter expresses precedence, the former expresses simultaneity or futurity, i.e., non-precedence.

- (18) Greta is ziek vandaag.
 Greta be.PRES ill today
 'Greta is ill today.'
- (19) Morgen loopt Jan de 100 meter.
 tomorrow run.PRES Jan the 100 meter
 'Jan runs the 100 meter tomorrow.'

The combination with a past time adjunct is highly unusual and stylistically marked, like in English.

- (20) ? Gisteren loopt Jan de 100 meter.
 yesterday run.PRES Jan the 100 meter

The semantic contribution of the Dutch present can, hence, be characterized as follows (IC-PRESENT).

$$\text{subst} \left[\text{CAT} \mid \text{HEAD} \mid \text{VFORM} \quad \textit{present} \right] \rightarrow \left[\begin{array}{l} \text{C-INDS} \left[\begin{array}{l} \text{LOC-TIME} \quad \boxed{1} \\ \text{UTT-TIME} \quad \boxed{2} \end{array} \right] \\ \text{BACKGROUND} \quad \left\{ \boxed{1} \not\prec \boxed{2} \right\} \end{array} \right]$$

How the time of location relates to the situation time is specified by IC-VERB and IC-EVENT.⁶ As a consequence, we expect that the tem-

⁶In contrast to the English present, the Dutch present is compatible with event type predicates, also if they stand for a single ongoing event. The sentence *Jan eet een hamburger*, for instance, can refer to a single event of eating which is going on at the time of utterance. In English, the expression of this meaning requires the use of the present progressive, as in *John is eating a hamburger* (Kamp and Reyle, 1993, 537).

poral extension of a state type predicate may exceed the length of the location time, whereas the one of an event type predicate may not. This expectation is indeed borne out.

- (21) Morgen wonen we hier precies twee jaar.
 tomorrow live.PRES we here precisely two year
 ‘Tomorrow we will have lived here for precisely two years.’
- (22) ? Morgen schrijf ik een boek in twee jaar.
 tomorrow write.PRES I a book in two year

In the state describing sentence it does not matter that the period of two years cannot be interpreted as part of tomorrow, since it is sufficient that they overlap, but in the event describing sentence, the resulting combination is not well-formed, since events require inclusion.

13.4 The Dutch Perfect

The formation of the Dutch perfect involves the use of two verbs: the auxiliary of the perfect, which is either *hebben* (‘have’) or *zijn* (‘be’), and the past participle of the main verb. Syntactically, the auxiliary is the head; it takes the participle as its most oblique argument, and inherits its other arguments from that participle.⁷

- (23)
$$\left[\begin{array}{l} \text{CATEGORY} \mid \text{HEAD} \quad \textit{verb} \\ \text{ARG-ST} \quad \boxed{\perp} \oplus \left\langle \left[\text{V}[\textit{psp}], \text{ARG-ST} \quad \boxed{\perp} \right] \right\rangle \end{array} \right]$$

Semantically, I will distinguish between two uses of the perfect.

13.4.1 The Aspectual Perfect

Some typical examples of the aspectual perfect are

- (24) Om tien uur had ik al drie klanten bezocht.
 at ten hour have.PAST I already three clients visit.PSP
 ‘At ten o’clock I had already visited three clients.’
- (25) Ik heb nu al drie klanten bezocht.
 I have.PRES now already three clients visit.PSP
 ‘I have already visited three clients now.’

These sentences describe a state which results from a completed event. In contrast to what happens in the simple tenses, the adjuncts

⁷Since only words have an ARG-ST feature, this analysis implicitly assumes that the participial complement is a lexical sign, rather than a phrasal one. This is compatible with the analysis of the Dutch *Mittelfeld* in van Noord and Bouma (1994).

om tien uur ('at ten o'clock') and *nu* ('now') do not specify the location time of the visits themselves, but rather the time at which the state of having paid the visits holds; the visits themselves are, hence, said to have taken place at some earlier time. Interestingly, this more complex interpretation can be derived in a purely compositional way.

For a start, let us assume that the auxiliary of the aspectual perfect has the following AVM.

$$(26) \left[\begin{array}{l} \text{CATEGORY} \mid \text{HEAD} \quad \textit{verb} \\ \text{ARG-ST} \quad \boxed{1} \oplus \left\langle \left[\text{V, ARG-ST } \boxed{1}, \text{SIT-TIME } \boxed{4} \textit{temp} \right] \boxed{3} \right\rangle \\ \text{CONTENT} \quad \left[\begin{array}{l} \text{INDEX} \quad \boxed{2} \textit{ref} \\ \text{RESTR} \quad \left\{ \begin{array}{l} \text{result-of} \left[\begin{array}{l} \text{INST } \boxed{2} \\ \text{SOA-ARG } \boxed{3} \textit{ref} \end{array} \right] \end{array} \right\} \end{array} \right] \\ \text{CONTEXT} \quad \left[\begin{array}{l} \text{C-INDS} \mid \text{SIT-TIME } \boxed{5} \textit{temp} \\ \text{BACKGROUND} \quad \left\{ \boxed{4} < \boxed{5} \right\} \end{array} \right] \end{array} \right]$$

The name of the predicate (*result-of*) is meant to generalize over *hebben* and *zijn*; it takes the index of the participle $\boxed{3}$ as its argument, and since the result of an action necessarily succeeds the action itself, its situation time $\boxed{5}$ is required to follow the one of the participle $\boxed{4}$.⁸ The latter is furthermore bounded, since the event is presented as completed; the former, on the other hand, is unbounded, since it denotes a state.

Since the AVM of the auxiliary unifies with the left hand side of IC-VERB, the situation time of the result state is related to a time of location, and if the auxiliary is tensed, the latter is further related to the time of utterance by either IC-PAST or IC-PRESENT. Incidentally, since the Dutch present allows for a futurate interpretation, we predict that the present perfect is compatible with future time adjuncts, and this prediction is indeed borne out.⁹

- (27) Morgen heb ik het gevonden; dat is zeker.
tomorrow have.PRES I it find.PSP; that is sure
'I will have found it by tomorrow; that is for sure.'

The participle, for its part, has its own AVM. If substantive, it will have its own index, situation time and location time, and—given IC-

⁸This corresponds to Reichenbach's constraint that E precede R in the perfect tenses.

⁹In English, this combination sounds awkward, since the English present is hardly ever used to express futurity in state describing sentences.

VERB—this time of location will be required to overlap the situation time. Moreover, since the participle describes a completed event, its situation time is bounded, and hence included in the location time, as required by IC-EVENT. As will be argued below, this is not only a property of the participle in aspectual perfect constructions, but a property of the Dutch past participle in general. To capture it I add the constraint IC-PSP.

$$subst \left[\begin{array}{l} CAT \mid HEAD \mid VFORM \quad psp \end{array} \right] \rightarrow \left[\begin{array}{l} C\text{-INDS} \left[\begin{array}{l} SIT\text{-TIME} \quad \boxed{2} \text{ temp} \\ LOC\text{-TIME} \quad \boxed{3} \text{ temp} \end{array} \right] \\ BACKGROUND \quad \{ \boxed{2} \subseteq \boxed{3} \} \end{array} \right]$$

This is a formal expression of the intuition that the Dutch past participle presents an eventuality as completed.¹⁰

Having specified the information which is carried by the auxiliary and the participle, we can now turn to their combination. The following tree, for instance, shows how the past participle interacts with the present forms of the perfect auxiliary.

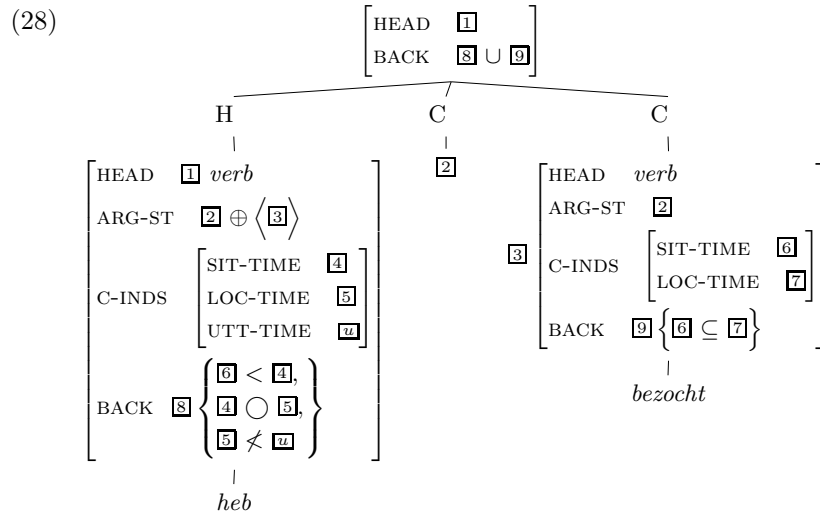

The temporal constraints of the present tense auxiliary and of the participle are included in their respective background values and passed on to the mother node, as stipulated in the Principle of Contextual Consistency: “The CONTEXT|BACKGROUND value of a given phrase is the

¹⁰Significantly, the standard term of the past participle in Dutch grammars is *voltwoord deelwoord* (‘completed participle’).

union of the CONTEXT|BACKGROUND values of the daughters.” (Pollard and Sag, 1994, 333) In this case, the four background restrictions are mutually compatible, so that the resulting temporal interpretation is consistent.

Since the resulting feature structure contains two times of location, the addition of a temporal adjunct may lead to ambiguity, as in

- (29) Ze had om vier uur al een hamburger gegeten.
 she have.PAST at four hour already a hamburger eat.PSP
 ‘She had already eaten a hamburger at four o’clock.’

In this sentence, the adjunct can apply to the location time of the auxiliary, meaning that the state of having eaten the hamburger held at four, but it can also apply to the location time of the participle, meaning that the eating itself took place at four.

Further evidence for this compositional analysis of the aspectual perfect can be extracted from the contrast in

- (30) Het sneeuwt nu al vier dagen.
 it snow.PRES now already four days
 ‘It has been snowing for four days now.’
- (31) Het heeft nu al vier dagen gesneeuwd.
 it have.PRES now already four days snow.PSP
 ‘It has already snowed for four days by now.’

The meanings of these sentences are similar, but their semantic analysis reveals a subtle difference. In the simple present sentence, there is only one situation time and this has to overlap the time of location, which is specified by *nu* (‘now’); as a consequence, the sentence is only true if it is snowing at (part of) the location time. For instance, if uttered on November 28, it will only be true if it started snowing on November 25 and is still snowing on the 28.

In the present perfect sentence, on the other hand, there are two situations, i.e., the process of snowing and the state which results from four days of snowing, and since it is only this state which has to overlap the location time of the auxiliary, it follows that the sentence can also be true if it is not snowing at the time of location. If uttered on November 28, for instance, the sentence is also true if the snowing took place in a period from say November 23 till November 26.

Summing up, this lexicalist analysis of the Dutch aspectual perfect does not only have the advantage of being strictly compositional, it also captures a salient but previously unnoticed contrast with the simple present.

13.4.2 The Past Time Perfect

As demonstrated in the previous paragraph, the aspectual present perfect expresses non-precedence, and is hence compatible with present and future time adjuncts, but not with past time adjuncts. In practice, though, the Dutch present perfect does combine with such adjuncts.

- (32) Hij heeft gisteren een verklaring afgelegd.
 he have.PRES yesterday a declaration make.PSP
 ‘He made a declaration yesterday.’

In contrast to the combination of the simple present with a past time adjunct, this combination is not unusual or marked.

To model this past time use of the present perfect we could stick to the analysis of the aspectual perfect and add the stipulation that the adjunct *gisteren* (‘yesterday’) does not specify the location time of the auxiliary here but rather the one of the participle. This would not only solve the incompatibility problem, it would also capture the fact that yesterday specifies the time of the declaration itself, rather than the temporal location of the state which results from that declaration.

In spite of these assets, though, the resulting analysis is not entirely satisfactory, since it still includes a result state, even though sentences like the above do not make any reference—neither implicit nor explicit—to a result state. They simply present some action as having taken place in the past. Significant in this respect is the fact that the English equivalent of this use of the present perfect is the simple past. Moreover, if the semantic analysis of a sentence like the above would include a non-past state, next to the past event, then it should be possible to add a present time adjunct, next to the past time *gisteren* (‘yesterday’), without creating any contradictions, but this is not the case: adding the adverb *nu* (‘now’), for instance, results in inconsistency.

More appropriate would be an analysis which contains only one time of location. In order to achieve this effect I will assume that the past time perfect lacks descriptive content. Unlike the aspectual perfect, which introduces a new verbal index and which denotes a predicate (*result-of*), the past time perfect simply relates the location time of its participial complement to the time of utterance without contributing any descriptive content of its own. In terms of the HPSG type hierarchy, its contribution concerns the CATEGORY and CONTEXT attributes, but not the CONTENT attribute. Technically, this can be implemented by distinguishing between two types of *local* objects.

- (33)
$$\begin{array}{c} \textit{local} \\ \hline \textit{substantive} \quad \textit{nonsubstantive} \end{array}$$

While all objects of type *local* have the attributes CATEGORY and CONTEXT, only the substantive ones have the CONTENT attribute.

$$(34) \quad \underset{local}{\left[\begin{array}{ll} \text{CATEGORY} & \text{category} \\ \text{CONTEXT} & \text{context} \end{array} \right]}$$

$$(35) \quad \underset{substantive}{\left[\text{CONTENT} \quad \text{content} \right]}$$

Being nonsubstantive, the auxiliary of the past time perfect is not subject to any of the implicational constraints which have been introduced so far. Instead, its contribution is specified lexically.

$$(36) \quad \underset{nonsubst}{\left[\begin{array}{l} \text{CATEGORY} \mid \text{HEAD} \mid \text{VFORM} \quad \textit{present} \\ \text{ARG-ST} \quad \boxed{1} \oplus \left\langle \left[\text{V}, \text{ARG-ST} \quad \boxed{1}, \text{LOC-TIME} \quad \boxed{2} \right] \right\rangle \\ \text{CONTEXT} \quad \left[\begin{array}{l} \text{C-INDS} \mid \text{UTT-TIME} \quad \boxed{3} \quad \textit{temp} \\ \text{BACKGROUND} \quad \{ \boxed{2} < \boxed{3} \} \end{array} \right] \end{array} \right]}$$

The location time of the participle is not related to the auxiliary's situation time (for the simple reason that the auxiliary has no situation time), but directly to the time of utterance. When combined with a past participle, the auxiliary is the syntactic head, but since it lacks a CONTENT attribute, it is the participle which functions as the semantic head.¹¹

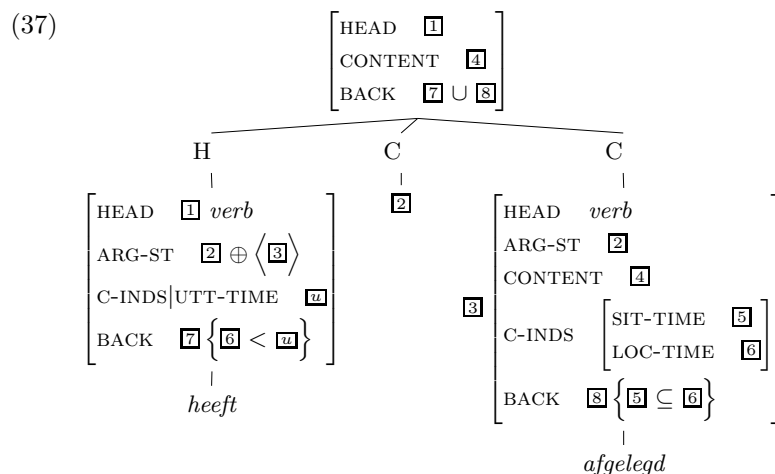

¹¹The dissociation of syntactic and semantic heads is by no means exceptional. In Pollard and Sag (1994), for instance, the adjuncts are treated as the semantic head in HEAD-ADJUNCT combinations.

Interestingly, the BACKGROUND value of the combination is identical to the one for the English simple past in event describing sentences.

Because of the nonsubstantive nature of the auxiliary, the combination has only one situation time and one location time. This explains why the past time perfect fails to show the scope ambiguities which are typical of the aspectual perfect: the adjunct *om vier uur* ('at four o'clock') in the next example, for instance, can only be understood as specifying the time of eating, i.e., the location time of the participle.

- (38) Gisteren heeft hij om vier uur een hamburger gegeten.
 yesterday have.PRES he at four hour a hamburger eat.PSP
 'Yesterday he ate a hamburger at four o'clock.'

The absence of a second time of location also helps to explain the contrast in

- (39) Het heeft nu al vier dagen gesneeuwd.
 it have.PRES now already four days snow.PSP
 'It has been snowing for four days now.'
- (40) ? Het heeft gisteren al vier dagen gesneeuwd.
 it have.PRES yesterday already four days snow.PSP

While the aspectual present perfect allows the combination of a temporal adjunct with a durational adjunct which exceeds its length, the past time perfect does not. This can be explained as follows: the constraint of the past participle that the situation time be included in the location time, can be satisfied in the first sentence, since the location time of the auxiliary, specified by *nu* ('now'), is distinct from the location time of the participle, but in the second sentence, this requirement cannot be met, since there is only one location time.

Because of its simpler semantic structure, the past time perfect has more in common with the simple past than with the aspectual perfect, but in spite of this similarity, their meanings are not identical. In state describing sentences, for instance, the past tense requires overlap with the location time, whereas the past time perfect requires inclusion, because of IC-PSP. This explains the contrast in

- (41) Hij was gisteren al een week ziek.
 he be.PAST yesterday already a week ill
 'He had been ill for a week (by) yesterday.'
- (42) ? Hij is gisteren al een week ziek geweest.
 he be.PRES yesterday already a week ill be.PSP

In sum, the past time perfect cannot be treated in the same compositional manner as the aspectual perfect, but this does not imply that we have to resort to non-monotonic techniques. All we need is a distinction between substantive and nonsubstantive signs, and the addition of a separate AVM for the auxiliary.

13.5 The Dutch Future

The Dutch auxiliary of the future is *zullen*. Syntactically, it is similar to the one of the perfect; the main difference is that it requires an infinitival complement instead of a participial one. Semantically, *zullen* is ambiguous in a way which resembles the perfect. In its substantive use, it is a modal verb, which contrasts with other modal verbs, such as *moeten* ('must'), *mogen* ('may') and *kunnen* ('can'). In its nonsubstantive use, it is the auxiliary of the future. Some typical examples of the future *zullen* are

- (43) Willy zal om vier uur de klokken luiden.
 Willy will.PRES at four hour the bells toll.INF
 'Willy will toll the bells at four o'clock.'
- (44) Morgen zullen we het weten.
 tomorrow will.PRES we it know.INF
 'We will know it tomorrow.'

Morphologically, the auxiliaries are in the present tense, but semantically they do not express non-precedence, but rather futurity.¹² They should, hence, be exempted from IC-PRESENT, and the way to do this is by now familiar. Instead of treating the auxiliary as a substantive verb with its own index and time of location, it is treated as a nonsubstantive verb, whose main function is to relate the location time of its complement to the time of utterance, as in

$$(45) \quad \left[\begin{array}{l} \text{CATEGORY | HEAD | VFORM } \textit{present} \\ \text{ARG-ST } \boxed{1} \oplus \left\langle \left[\text{V, ARG-ST } \boxed{1}, \text{LOC-TIME } \boxed{2} \right] \right\rangle \\ \text{CONTEXT } \left[\begin{array}{l} \text{C-INDS | UTT-TIME } \boxed{3} \textit{temp} \\ \text{BACKGROUND } \{ \boxed{2} > \boxed{3} \} \end{array} \right] \end{array} \right]_{\textit{nonsubst}}$$

Since a combination of this auxiliary with an infinitive contains only one time of location, it is predicted that there cannot be any scope

¹²The present tense of the modal *zullen* expresses non-precedence, as is normal for a substantive verb. The modal use of the auxiliary will not be analyzed in this paper.

ambiguities for the temporal adjuncts, depending on whether they apply to the entire finite VP or only to the infinitive. This prediction is indeed borne out. In the sentence above, for instance, *om vier uur* can only be understood as the time at which the bells will be ringing, and not as a time which precedes that event.

The analysis of the future auxiliary closely resembles the one of the past time perfect, but apart from the obvious difference in meaning (future vs. past), there is another more subtle difference. For, since its complement is an infinitive instead of a participle, the situation time need not be included in the time of location; instead, given IC-VERB, all that is required is overlap, at least in sentences with an unbounded temporal extension, and this explains why the following sentence is well-formed.

- (46) Morgen zullen we hier precies tien jaar wonen.
 tomorrow will.PRES we here precisely ten year live.INF
 ‘Tomorrow we will have lived here for precisely ten years.’

Ten years cannot be included in a day, but this does not matter, since temporal overlap is sufficient.

When the auxiliary of the future is combined with the aspectual perfect, one gets the so-called future perfect, as in

- (47) Voor het einde van de dag zal de haan drie maal
 before the end of the day will.PRES the cock three time
 gekraaid hebben.
 crow.PSP have.INF
 ‘Before the end of the day the cock will have crowed three times.’

This combination contains two substantive verbs, and hence two times of location. The one of the perfect auxiliary is specified by *voor het einde van de dag* (‘before the end of the day’), and marks the time at which the state obtains which results from the three crowing events. The function of the nonsubstantive future auxiliary is to relate that time of location to the time of utterance.

13.6 Conclusion

Combining insights from Davidson, Reichenbach and Discourse Representation Theory, I have developed a constraint-based semantics for the Dutch tenses and temporal auxiliaries, and integrated it in the HPSG framework. The core of the analysis is a set of five implicational constraints (IC-VERB, IC-EVENT, IC-PAST, IC-PRESENT, IC-PSP), which, when applied to the AVMS of individual verbal signs, specify their temporal meanings. If a clause contains more than one verb, its temporal

meaning can be derived compositionally from the temporal constraints which are associated with the individual verbs. Apparent counterexamples, such as the past time perfect and the future, were brought into line, by the introduction of a sortal distinction between substantive and nonsubstantive signs, the stipulation that the implicational constraints only apply to substantive verbs, and the addition of two lexical AVMs. Further evidence for the distinction between substantive and nonsubstantive signs is provided in Van Eynde (2000), where it is applied to the English auxiliaries.

When compared to the rule-based treatment of the syntax/semantics interface in DRT, this constraint-based treatment has the advantages of being non-directional, fully explicit and comparatively simple. More specifically, DRT's irreversible construction rules which are a mixture of formal notation and prose, and which often take a full page of text, have been replaced by a small set of fully formalized implicational constraints and lexical specifications.

References

- Binnick, R. 1991. *Time and the verb. A guide to tense and aspect*. New York/Oxford: Oxford University Press.
- Davidson, D. 1967. The logical form of action sentences. In N. Rescher, ed., *The logic of decision and action*. University of Pittsburgh Press.
- Kamp, H. and U. Reyle. 1993. *From Discourse to Logic. Introduction to Modeltheoretic Semantics of Natural Language, Formal Logic and Discourse Representation Theory*. Dordrecht/Boston/London: Kluwer Academic Publishers.
- Parsons, T. 1990. *Events in the Semantics of English*, vol. 19 of *Current Studies in Linguistics*. MIT Press.
- Pollard, C. and I. Sag. 1994. *Head-driven Phrase Structure Grammar*. Stanford/Chicago: CSLI and University of Chicago Press.
- Reichenbach, H. 1947. *Elements of Symbolic Logic*. New York: The Free Press. reprint (1966).
- Sag, I. and T. Wasow. 1999. *Syntactic Theory. A formal introduction*. CSLI Publications.
- Sanfilippo, A. 1990. *Grammatical Relations, Thematic Roles and Verb Semantics*. Ph.D. thesis, University of Edinburgh.
- Schelkens, N., F. Van Eynde, and S. Verdoolaege. 2000. The Semantics of Temporal Adjuncts. In P. Monachesi, ed., *Computational Linguistics in the Netherlands 1999*. Utrecht: University of Utrecht.

- Van Eynde, F. 1998. Tense, Aspect and Negation. In F. Van Eynde and P. Schmidt, eds., *Linguistic Specifications for Typed Feature Structure Formalisms*, vol. 10 of *Studies in Machine Translation and Natural Language Processing*, pages 209–280. Luxembourg: Office for Official Publications of the European Communities.
- Van Eynde, F. 2000. Figure Heads in HPSG. In F. Van Eynde, I. Schuurman, and N. Schelkens, eds., *Computational Linguistics in the Netherlands 1998*, pages 161–178. Amsterdam/Atlanta: Rodopi.
- van Noord, G. and G. Bouma. 1994. Adjuncts and the Processing of Lexical Rules. In *Proceedings of the 15th International Conference on Computational Linguistics (Coling)*, pages 250–256. Kyoto: University of Kyoto.
- Verkuyl, H. 1993. *A Theory of Aspectuality. The Interaction between Temporal and Atemporal Structure*, vol. 64 of *Cambridge Studies in Linguistics*. Cambridge University Press.