

Pied piping in English interrogatives

Frank Van Eynde
Centre for Computational Linguistics
University of Leuven – Belgium

Universität Göttingen
December 13, 2006

Overview

1. Some data
2. The nonlocal head-driven treatment of Ginzburg and Sag 2000
3. Problems for the nonlocal head-driven treatment
4. A local functor-driven treatment
5. Extensions
6. Wh-intensifiers
7. Conclusion

1 Some data

- (1) a. You said WHAT ?
b. Who told WHAT to WHOM ?
- (2) a. *What* did you say __?
b. I do not know *what* she said __.
- (3) a. I wonder *which train* we should take __.
b. *How long* are they going to stay __?

“As a rule, (i) the *wh*-element (*ie* the clause element containing the *wh*-word) comes first in the sentence; (ii) the *wh*-word itself takes first position in the *wh*-element. The only exception to the second principle occurs when the *wh*-word is within a prepositional complement.” (Quirk, Greenbaum, Leech and Svartvik 1985, 817)

- (4) a. *Whom* did you send that letter to __?
b. *To whom* did you send that letter __? <formal>

“a feature percolation approach with the (not implausible) proviso that percolation of this kind is limited to left branches, modulo a preceding preposition.” (Van Riemsdijk 1994, 332)

- (5) a. * I wonder *take which train* we should __.
b. * I do not know *proud of what* we should be __.
c. * *Friends of whom* did they invite __?

The linear order constraint does not account for:

- (6) a. I wonder *whose* leaving the room she was referring to __.
b. * I wonder *who(m)* leaving the room she was referring to __.
- (7) a. * I wonder *which* we should take __ train.
b. * *How* are they going to stay __ long?
- (8) a. *How much of the wine* did they drink __ ?
b. *How much* did they drink __ of the wine ?
c. * *How* did they drink __ much of the wine ?

2 The nonlocal head-driven treatment of GS-2000

(9) I do not know which toy they gave her ...

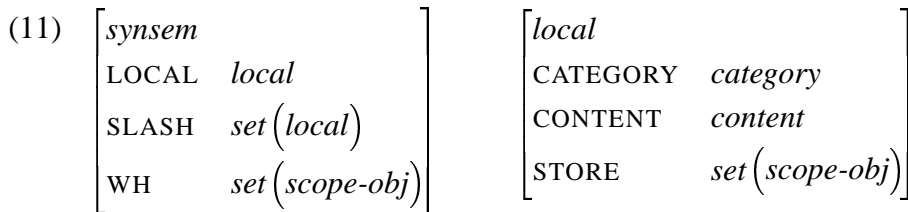
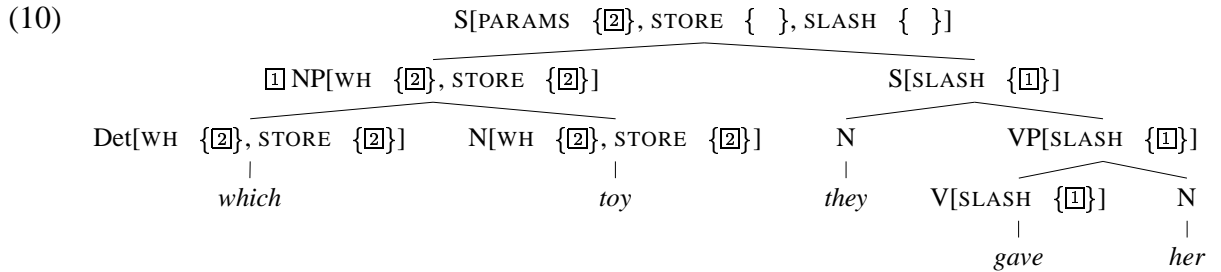

2.1 Extraction

2.1.1 The lexical grounding

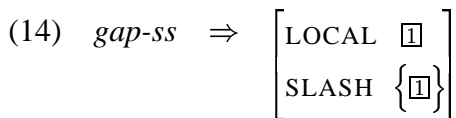
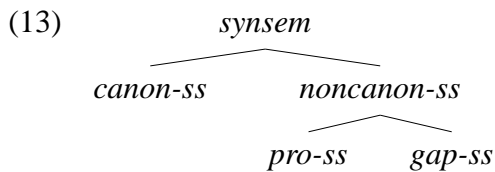
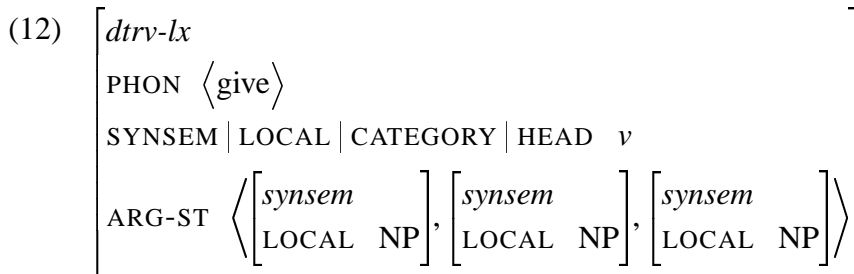

$$(15) \left[\begin{array}{l} \text{word} \\ \text{PHON} \langle \text{gave} \rangle \\ \text{SYNSEM} \mid \text{LOCAL} \mid \text{CATEGORY} \mid \text{HEAD} \mid \text{VFORM } \textit{finite} \\ \text{ARG-ST} \left\langle \left[\begin{array}{l} \textit{canon-ss} \\ \text{LOCAL NP } [nom] \end{array} \right], \left[\begin{array}{l} \textit{canon-ss} \\ \text{LOCAL NP} \end{array} \right], \left[\begin{array}{l} \textit{gap-ss} \\ \text{LOCAL } \boxed{3} \text{ NP} \\ \text{SLASH } \{ \boxed{3} \} \end{array} \right] \right\rangle \end{array} \right]$$

$$(16) \text{ ARGUMENT REALIZATION PRINCIPLE (GS-2000, 171)} \\ \text{word} \Rightarrow \left[\begin{array}{l} \text{SYNSEM} \mid \text{LOCAL} \mid \text{CAT} \left[\begin{array}{l} \text{SUBJ} \quad \boxed{A} \\ \text{SPR} \quad \quad \boxed{B} \\ \text{COMPS} \quad \boxed{C} \ominus \textit{list}(\textit{gap-ss}) \end{array} \right] \\ \text{ARG-ST} \quad \boxed{A} \oplus \boxed{B} \oplus \boxed{C} \end{array} \right]$$

$$(17) \left[\begin{array}{l} \text{word} \\ \text{PHON} \langle \text{gave} \rangle \\ \text{SYNSEM} \mid \text{LOCAL} \mid \text{CATEGORY} \left[\begin{array}{l} \text{HEAD} \mid \text{VFORM } \textit{finite} \\ \text{SUBJ} \langle \boxed{1} \rangle \\ \text{SPR} \langle \rangle \\ \text{COMPS} \langle \boxed{2} \rangle \end{array} \right] \\ \text{ARG-ST} \left\langle \boxed{1} \left[\begin{array}{l} \textit{canon-ss} \\ \text{LOCAL NP } [nom] \end{array} \right], \boxed{2} \left[\begin{array}{l} \textit{canon-ss} \\ \text{LOCAL NP} \end{array} \right], \left[\begin{array}{l} \textit{gap-ss} \\ \text{LOCAL } \boxed{3} \text{ NP} \\ \text{SLASH } \{ \boxed{3} \} \end{array} \right] \right\rangle \end{array} \right]$$

$$(18) \text{ SLASH AMALGAMATION CONSTRAINT (GS-2000, 169)} \\ \text{word} \Rightarrow / \left[\begin{array}{l} \text{SS} \mid \text{SLASH } \boxed{S}_1 \cup \dots \cup \boxed{S}_n \\ \text{ARG-ST} \langle [\text{SLASH } \boxed{S}_1], \dots, [\text{SLASH } \boxed{S}_n] \rangle \end{array} \right]$$

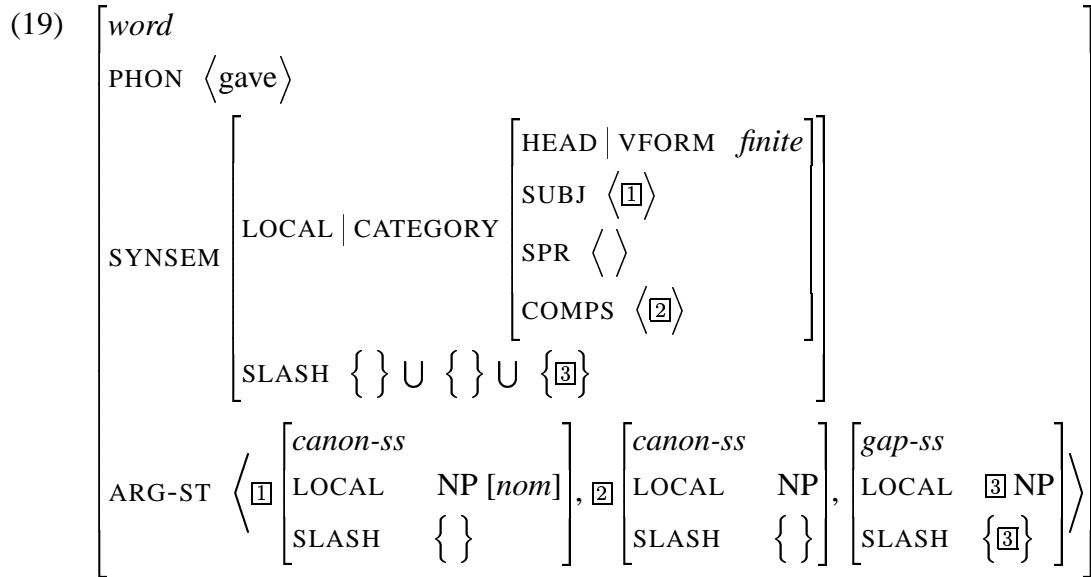

2.1.2 The head-driven propagation

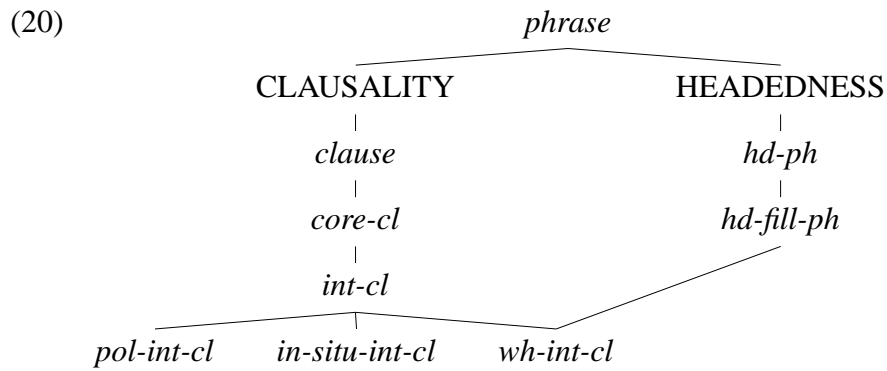

(21) GENERALIZED HEAD FEATURE PRINCIPLE (GS-2000, 33)

hd-ph:

[SYNSEM / 1] → ... **H**[SYNSEM / 1] ...

2.1.3 The construction-based termination

(22) *hd-fill-ph*:

$$[\text{SLASH } \boxed{S}] \rightarrow [\text{LOCAL } \boxed{I}], \mathbf{H} \left[\begin{array}{l} \textit{phrase} \\ \text{HEAD } v \\ \text{SLASH } \{ \boxed{I} \} \uplus \boxed{S} \end{array} \right]$$

2.2 Pied piping

Interrogative *wh*-words: the pronominal *who(m)*, *whose*, *what*, *which* and the adverbial *when*, *where*, *why*, *how*.

$$(23) \left[\begin{array}{l} \text{LOCAL} \left[\begin{array}{l} \text{CONTENT } \boxed{I} \textit{parameter} \\ \text{STORE } \{ \boxed{I} \} \end{array} \right] \\ \text{WH } \{ (\boxed{I}) \} \end{array} \right]$$

(24) I wonder *what* she told __ to WHOM.

“The generalization that follows from our analysis is that only the first interrogative *wh*-word in an interrogative clause will bear a nonempty WH value.” (Ginzburg and Sag 2000, 186)

(25) WH-AMALGAMATION CONSTRAINT (GS-2000, 189)

$$\textit{word} \Rightarrow / \left[\begin{array}{l} \text{SS} | \text{WH } \boxed{S}_1 \cup \dots \cup \boxed{S}_n \\ \text{ARG-ST } \langle [\text{WH } \boxed{S}_1], \dots, [\text{WH } \boxed{S}_n] \rangle \end{array} \right]$$

(26) I do not know *to whose friends* they sent presents ___

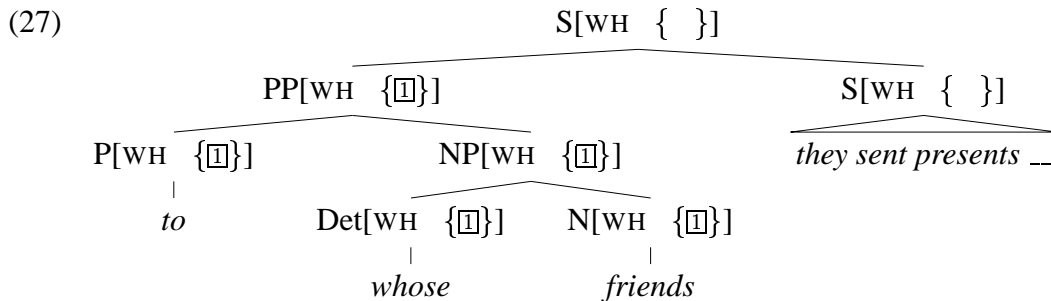

(28) a. *Whose cousin's friend's dog* is she going to buy ___?

b. *How much smarter (than Paul)* do you think she really is ___?

- (29) a. * I wonder *take which train* we should ...
 b. * I do not know *proud of what* we should be ...
 c. * *Friends of whom* did they invite ...?
- (30) WH-CONSTRAINT (GS-2000, 189)
 Any non-initial element of a lexeme's ARG-ST list must be [WH { }].
- (31) I wonder *whose/*whom* leaving the room she was referring to ...
- (32) WH-SUBJECT PROHIBITION (GS-2000, 189)
 $word \Rightarrow \left[SS | LOC | CAT | SUBJ \ list \left(\left[WH \ \{ \} \right] \right) \right]$

The *wh*-word in *who ... left* is not a subject but a filler (Hukari and Levine 1996).

2.3 Storage

- (33) STORE AMALGAMATION CONSTRAINT (GS-2000, 205)
 $word \Rightarrow / \left[\begin{array}{l} SS | LOC | STORE \ \boxed{S_1} \cup \dots \cup \boxed{S_n} \\ ARG-ST \ \langle [STORE \ \boxed{S_1}], \dots, [STORE \ \boxed{S_n}] \rangle \end{array} \right]$
- (34) INTERROGATIVE RETRIEVAL CONSTRAINT (GS-2000, 227)
inter-cl:

$$\left[\begin{array}{l} SS | LOC \ \left[\begin{array}{l} CONTENT | PARAMS \ \boxed{S_2} \\ STORE \ \boxed{S_1} \end{array} \right] \\ HEAD-DTR | SS | LOC | STORE \ \boxed{S_1} \uplus \boxed{S_2} \end{array} \right]$$
- (35) You asked *which book* Sandy gave -- to WHO(M) ?
- (36) FILLER INCLUSION CONSTRAINT (GS-2000, 228)
wh-int-cl:
 $\left[CONTENT | PARAMS \ \{ \boxed{1} \} \uplus set \right] \rightarrow \left[WH \ \{ \boxed{1} \} \right], \mathbf{H}$

3 Problems for the nonlocal head-driven treatment

3.1 The formalization

The WH-CONSTRAINT is the only constraint in GS-2000 which is not expressed in TFS terms. It is also the only lexical constraint which applies to lexemes rather than to words.

3.2 NPs

- (37) a. *Which/whose suitcase* did you take -- ?
 b. * I wonder *friends of whom* they visited ---.

$$(38) \begin{bmatrix} cn-lx \\ SS | LOC | CAT | HEAD \ n \\ ARG-ST \ \langle \text{DET} \rangle \oplus \boxed{A} \end{bmatrix}$$

- (39) SINGULAR ATTRIBUTIVE NOUN LEXICAL RULE (GS-2000, 190)

$$\begin{bmatrix} lx \\ SS | LOC | CAT | HEAD \ n \end{bmatrix} \Rightarrow_{LR} \begin{bmatrix} word \\ SS | LOC | CAT \ \left[\begin{array}{l} HEAD \ \left[\begin{array}{l} AGR | NUM \ sg \\ PRED \ - \end{array} \right] \\ SUBJ \ \langle \rangle \\ SPR \ \langle \boxed{I} \rangle \end{array} \right] \\ ARG-ST \ \langle \boxed{I} \rangle \oplus \boxed{A} \end{bmatrix}$$

- (40) *bare-nom-ph*:

$$\left[SPR \ \langle \rangle \right] \rightarrow \mathbf{H} \begin{bmatrix} HEAD \ n \\ SPR \ \left\langle \begin{array}{l} DET \\ \left[WH \ \{ \} \right] \end{array} \right\rangle \end{bmatrix}$$

The SPR list must be nonempty, both in lexemes and words, also if there is no specifier.

Nonbranching rules have the effect of blurring the word/phrase distinction (GS-2000, 199).

The use of nonbranching rules for XP to X' (or X) is at odds with the elimination of nonbranching rules for X' to X: "Because the list of nonhead daughters must be nonempty [in a *hd-comp-ph* – FVE], a strictly intransitive lexical head—one whose COMPS list is empty—cannot head a *hd-comp-ph*." (Ginzburg and Sag 2000, 34)

- (41) a. I wonder *whose suitcase* this might be ...
 b. * I wonder *the suitcase of whom* this might be ...

(42) SINGULAR PREDICATIVE NOUN LEXICAL RULE (GS-2000, 409)

$$\left[\begin{array}{l} lx \\ SS | LOC | CAT | HEAD \ n \\ ARG-ST \langle \boxed{1} \rangle \oplus \boxed{A} \end{array} \right] \Rightarrow_{LR} \left[\begin{array}{l} word \\ SS | LOC | CAT \\ ARG-ST \langle \boxed{2}, \boxed{1} \rangle \oplus \boxed{A} \end{array} \left[\begin{array}{l} HEAD \left[\begin{array}{l} AGR | NUM \ sg \\ PRED \ + \end{array} \right] \\ SUBJ \langle \boxed{2} \rangle \\ SPR \langle \boxed{1} \rangle \end{array} \right] \right]$$

The SUBJ list must be empty for lexemes, but non-empty for nouns which head a predicative NP.

3.3 Predicative APs

- (43) a. I wonder *how honest* Sandy really is ...
 b. * I wonder *proud of whom* Sandy really is ...

$$(44) \left[\begin{array}{l} a-lx \\ SS | LOC | CAT | HEAD \ a \\ ARG-ST \langle NP \rangle \oplus \boxed{A} \end{array} \right]$$

There is a (nondefined) lexical rule which maps this onto:

$$(45) \left[\begin{array}{l} word \\ SS \left[\begin{array}{l} LOC | CAT \\ WH \ \boxed{5} \end{array} \right] \left[\begin{array}{l} HEAD \left[\begin{array}{l} a \\ PRED \ + \\ DEG \ \boxed{3} \end{array} \right] \\ SUBJ \langle \boxed{1} \rangle \\ SPR \langle \boxed{2} \rangle \\ COMPS \ \boxed{A} \end{array} \right] \\ ARG-ST \left\langle \boxed{1} \left[\begin{array}{l} NP \\ WH \ \{ \} \end{array} \right], \boxed{2} \left[\begin{array}{l} DET \\ WH \ \boxed{5} \\ DEG \ \boxed{3} \end{array} \right] \right\rangle \oplus \boxed{A} \end{array} \right]$$

3.5 PPs

Case marking prepositions: ARG-ST <NP>

- (53) I wonder *to whom* they gave the money ...

Predicating prepositions: ARG-ST <NP , NP>

- (54) a. I wonder *which countries* they have been in ...
b. ? I wonder *in which countries* they have been ...

Prepositions in modifiers: ARG-ST <XP , NP>

- (55) *How long before the departure* do we have to be ready ...?
(56) a. *Since when* do I have to explain my actions to you ...?
b. *During which years* were you living in Germany ...?
c. I wonder *after which party* Poirot met Maigret ...
d. I wonder *in what way* John will feed the pigs ...
(57) a. * *When* do I have to explain my actions to you since ...?
b. * *Which years* were you living in Germany during ...?
c. * I wonder *which party* Poirot met Maigret after ...
d. * I wonder *what way* John will feed the pigs in ...

3.6 What with coordination ?

- (58) a. *When* and *where* did they meet ... ?
b. *How* and *why* did it happen ... ?

3.7 Local or nonlocal ?

- (59) *Who* [do you think [she said [... will be elected]]] ?
(60) a. * I wonder *which* [I think [she said [... train]]] we should take.
b. * *How big* [I think [she said [... a risk]]] is she prepared to take ?
c. * *How many* [I think [she said [... of those jewels]]] did she choose ?
(61) a. *How* she did it ... nobody knows.
b. *Welches Buch* Maria liest ..., weisz Max.

See also (Holler-Feldhaus 2001)

4 A local functor-driven treatment

- (62) a. *Whose cousin's friend's dog* is she going to buy ...?
 b. *How much smarter (than Paul)* do you think she really is ...?
- (63) a. *There* seems to have been some misunderstanding.
 b. We expected *there* to have been some accidents.

Instead of introducing a device which overgenerates (the WhAC) and then adding constraints which reduce it (WhC and WhSP), I use a device which undergenerates (section 4) and then add some ways to enhance it (section 5).

4.1 Functor-driven pied piping

- (64)
$$\left[\begin{array}{l} \text{category} \\ \text{HEAD} \left[\begin{array}{l} \textit{part-of-speech} \\ \text{SELECT } \textit{synsem} \vee \textit{none} \end{array} \right] \\ \text{SUBJ } \textit{list}(\textit{synsem}) \\ \text{COMPS } \textit{list}(\textit{synsem}) \\ \text{MARKING } \textit{marking} \end{array} \right]$$
- $$\begin{array}{c} \textit{marking} \\ \swarrow \quad \searrow \\ \textit{marked} \quad \textit{unmarked} \end{array}$$

See also (Soehn and Sailer 2003)

- (65)
$$\begin{array}{c} \textit{phrase} \\ \swarrow \quad \searrow \\ \text{CLAUSALITY} \quad \text{HEADEDNESS} \\ | \quad \quad \quad | \\ \textit{clause} \quad \quad \quad \textit{hd-ph} \\ | \quad \quad \quad \swarrow \quad \searrow \\ \textit{core-cl} \quad \quad \quad \textit{hd-mark-ph} \quad \textit{non-hd-mark-ph} \\ | \quad \quad \quad \swarrow \quad \searrow \quad \quad \quad \swarrow \quad \searrow \\ \textit{int-cl} \quad \quad \quad \textit{hd-fun-ph} \quad \dots \quad \textit{hd-comp-ph} \quad \dots \quad \textit{hd-fill-ph} \\ \swarrow \quad \searrow \quad \quad \quad \swarrow \quad \searrow \\ \dots \quad \textit{wh-int-cl} \quad \quad \quad \dots \quad \dots \quad \dots \end{array}$$

- (66) HEAD FEATURE PRINCIPLE (Pollard and Sag 1994)

$$\left[\begin{array}{l} \textit{hd-ph} \\ \text{SS} \mid \text{LOC} \mid \text{CAT} \mid \text{HEAD} \quad \boxed{1} \textit{head} \\ \text{HEAD-DTR} \mid \text{SS} \mid \text{LOC} \mid \text{CAT} \mid \text{HEAD} \quad \boxed{1} \end{array} \right]$$

- (67) GENERALIZED MARKING PRINCIPLE (after PS-1994, 45)

- a. $\left[\begin{array}{l} hd\text{-}mark\text{-}ph \\ SS | LOC | CAT | MARKING \quad \boxed{1} \textit{marking} \\ MARK\text{-}DTR | SS | LOC | CAT | MARKING \quad \boxed{1} \end{array} \right]$
- b. $\left[\begin{array}{l} non\text{-}hd\text{-}mark\text{-}ph \\ SS | LOC | CAT | MARKING \quad \boxed{1} \textit{marking} \\ HEAD\text{-}DTR | SS | LOC | CAT | MARKING \quad \boxed{1} \end{array} \right]$

- (68) $\left[\begin{array}{l} hd\text{-}fun\text{-}ph \\ MARK\text{-}DTR | SS | LOC | CAT | HEAD | SELECT \quad \boxed{1} \\ HEAD\text{-}DTR | SS \quad \boxed{1} \textit{synsem} \end{array} \right]$

See (Van Eynde 1998) and (Allegranza 1998).

- (69)
-
- ```

graph TD
 N3["N[MARK 3]"] --- N3m["N[3 marked]"]
 N3 --- N2["N[MARK 2]"]
 N3m --- his["his"]
 N2 --- A2["A[2 unmarked]"]
 N2 --- N1["N[MARK 1]"]
 A2 --- many["many"]
 N1 --- A1["A[1 unmarked]"]
 N1 --- N["N[MARK unmarked]"]
 A1 --- beautiful["beautiful"]
 N --- pictures["pictures"]

```

This excludes *beautiful his pictures* and *the his pictures*. If one treats the pronouns as inherently marked, it also excludes *the him* and *every who*.

Proposal: integration of WH in the MARKING values (Van Eynde 2004)

- (70)  $\left[ \begin{array}{l} marking \\ WH \quad wh \end{array} \right]$
- 
- ```

graph TD
    wh["wh"] --- negative["negative"]
    wh --- positive["positive"]
  
```

The interrogative *wh*-words are inherently marked and receive the underspecified value *wh*.

- (71) $\left[\begin{array}{l} word \\ SS | LOC \left[\begin{array}{l} CAT | MARKING \left[\begin{array}{l} marked \\ WH \quad wh \end{array} \right] \\ CONTENT \quad parameter \end{array} \right] \right] \\ ARG\text{-}ST \quad \langle \rangle \end{array} \right]$

- (72) I wonder *what* she said -- to *whom*.

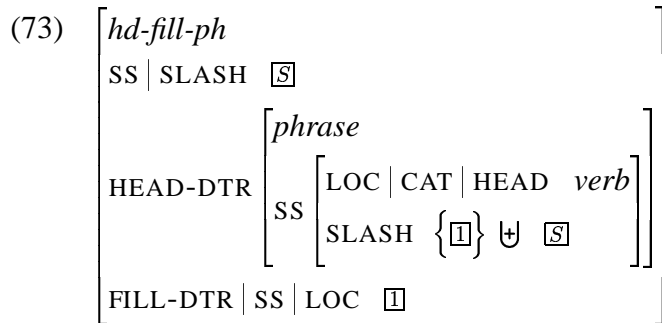

(74) FILLER INCLUSION CONSTRAINT (ADAPTED)

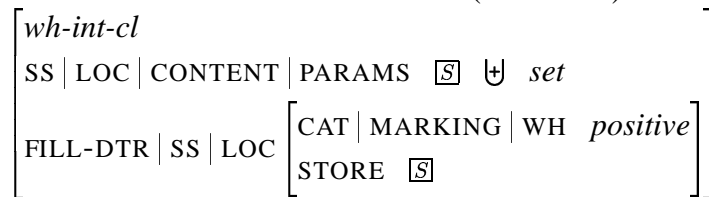

(75) Which athletes of which countries are they going to invite -- ?

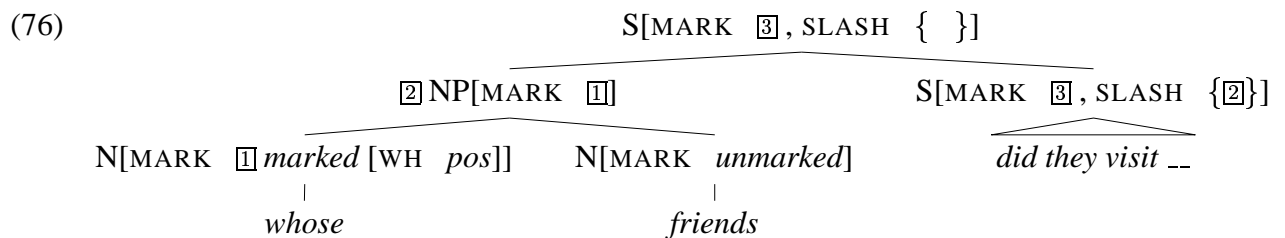

Iterative propagation of the MARKING value:

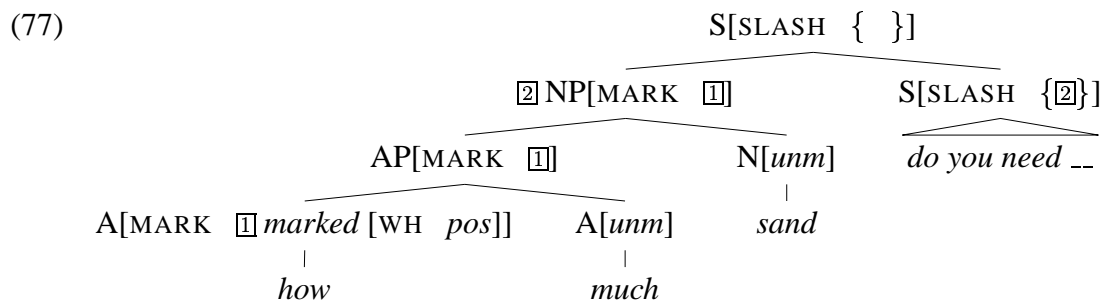

The WH value is propagated directly from the functor daughter to the mother without mediation of the head daughter.

- (78) a. * I wonder *take which train* we should ...
 b. * I do not know *proud of what* we should be ...
 c. * I do not know (*the*) *friends of whom* they have invited ...

(79) * I wonder *whom leaving the room* she was referring to __.

(80) a. * I wonder *which* we should take __ train.

b. * *How* did they drink __ much of the wine ?

c. * I wonder *whose* we should sell __ car.

d. * *What* do you prefer __ framework ?

(81)
$$\left[\begin{array}{l} \textit{word} \\ \text{SS} | \text{LOC} | \text{CAT} \left[\begin{array}{l} \text{HEAD} | \text{SELECT} \textit{ synsem} \\ \text{MARKING} | \text{WH} \textit{ pos} \end{array} \right] \end{array} \right] \Rightarrow \left[\text{SS} | \text{LOC} | \text{CAT} | \text{HEAD} | \text{SELECT} \textit{ canon-ss} \right]$$

5 Extensions

5.1 Pied piping in PPs

- (82) a. I do not know *to whom* they sent that letter ___.
 b. *In whose house* are they staying ___?
 c. I do not remember *after which party* she got ill ___.

$$(83) \quad p-lx \Rightarrow \left[\begin{array}{l} \text{SS} \mid \text{LOC} \mid \text{CAT} \left[\begin{array}{l} \text{HEAD } \textit{prep} \\ \text{COMPS} \left\langle \left[\text{LOC} \mid \text{CAT} \mid \text{MARKING} \mid \text{WH} \quad \boxed{1} \right] \right\rangle \\ \text{MARKING} \mid \text{WH} \quad \boxed{1} \end{array} \right] \end{array} \right]$$

- (84) a. * I do not know *right to whom* they threw the ball ___.
 b. * I do not remember *just after which party* she got ill ___
 (85) *How long after the deadline* can we send our paper ___?

5.2 Coordination

- (86) a. *When* and *where* did they meet ___ ?
 b. *How* and *why* did it happen ___ ?

- (87) COORDINATION PRINCIPLE (PS-1994, 202-3)

In a coordinate structure, the CATEGORY and NONLOCAL value of each conjunct daughter is identical to (or at least subsumed by) that of the mother.

5.3 Predeterminers

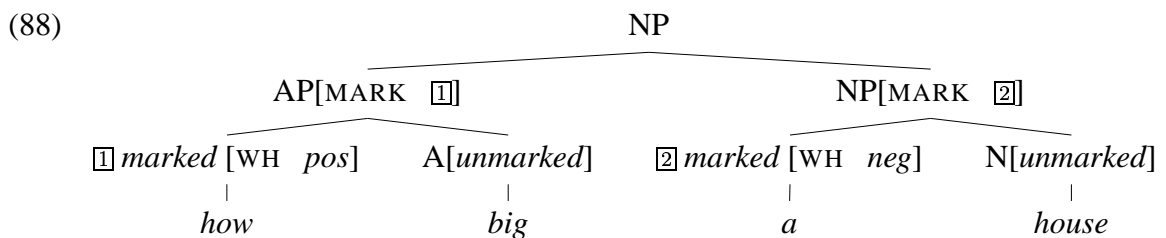

This excludes *a how/too/so big house*.

Why the AP cannot be a functor of the NP: *big a house* vs. *how/so/too/that big a house*.

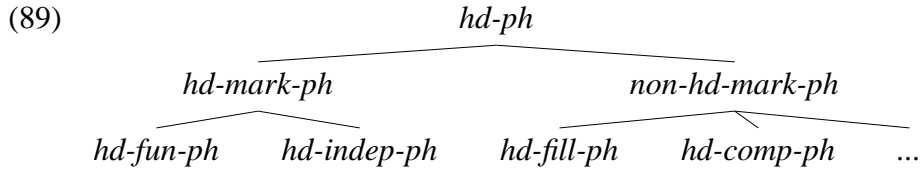

See (Van Eynde 1998) and (Van Eynde 2005).

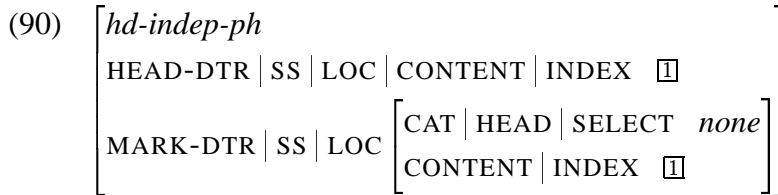

- (91)
- a. Witte en zwarte hemden
white-DCL and black-DCL shirts
shirts which are white and shirts which are black
 - b. wit en zwarte hemden
white and black-DCL shirts
shirts which are black-and-white
 - c. Zijn beste vriend en zijn lief hebben hem bedrogen.
his best friend and his girlfriend have him cheated
his best friend has cheated on him and his girlfriend has cheated on him
 - d. Zijn beste vriend en kamergenoot heeft hem bedrogen.
his best friend and roommate has him cheated
his best friend and roommate has cheated on him

- (92)
- a. de Frans-Duitse grens
the French-German-DCL border
'the Franco-German border'
 - b. in u beider voordeel
in you-ACC both-GEN advantage
'to the advantage of both of you'
 - c. Jan zijn fiets, Marie haar tuin
John his bike, Mary her garden
'John's bike, Mary's garden'

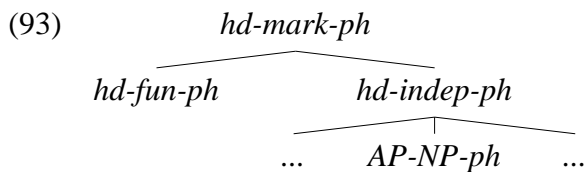

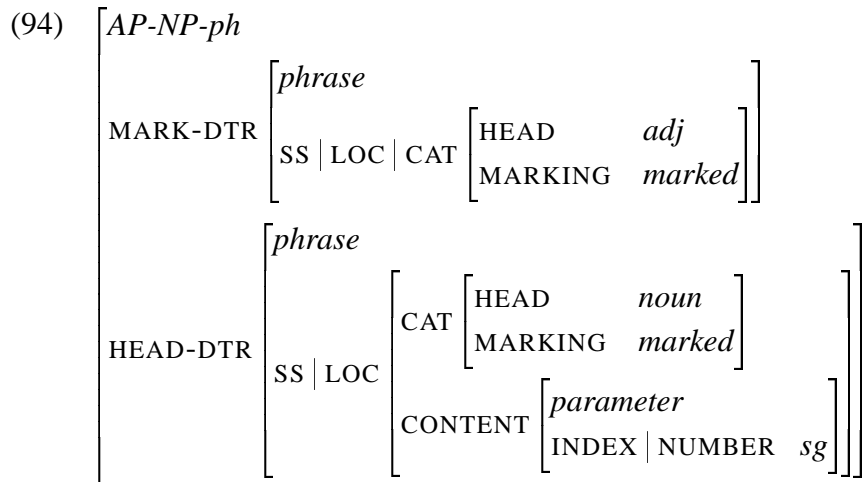

- The AP must be phrasal: * *big a house*.
- The AP must be marked: * *very big a house*.
- The NP must be phrasal: * *how big anyone*.
- The NP must be marked: * *how nice warm water*.
- The NP must be of type *parameter*: * *so big some house*.
- The NP must be singular: * *so big many houses*.

The net result is that the NP must be introduced by a non-quantifying use of the indefinite article.

5.4 Possessive NPs

The clitic in *John's bike* is a reduced possessive pronoun, comparable to the reduced personal pronoun in *let's dance*.

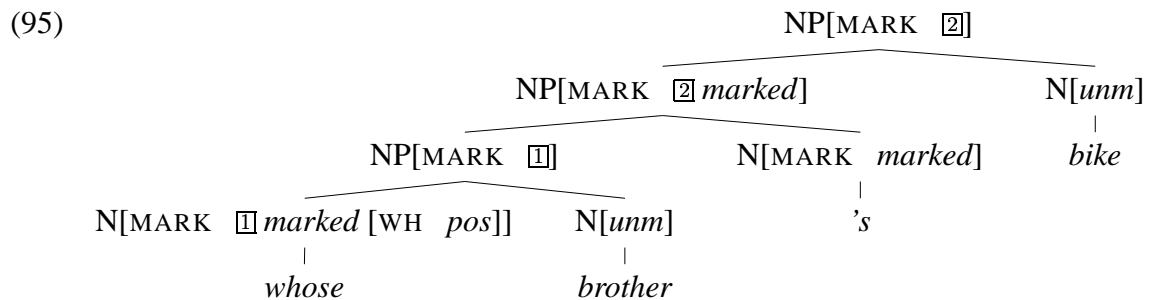

Why the lower NP cannot be a functor of the clitic.

6 The *wh*-intensifiers

Interrogative *wh*-words may be followed by an intensifier:

- NPs: *the hell, the heck, the devil, the deuce, the fuck, the blazes*
- PPs: *on earth, in the world, in heaven's name, in God's name, in tarnation, in blue blazes.*

- (97) a. *Who the hell* did she visit __?
 b. * *She visited WHO the hell* ?

The modifier treatment (GS-2000, 229)

- (98) [SS | LOC | CAT | HEAD | MOD | WH {*parameter*}]

“These modifiers must be further constrained so as to modify interrogative *wh*-words (not *wh*-phrases).” (GS-2000, 229)

- (99) a. *Which the heck book* did he read __?
 b. * *Which book the heck* did he read __?
- (100) a. *How the hell many books* did they buy __?
 b. * *How many the hell books* did they buy __?
 c. * *How many books the hell* did they buy __?

- Lexical selection via HEAD|MOD is inadequate: *what this devil* and *who in the sea*.
- The intensifiers do not restrict the denotation of their head sister, as modifiers canonically do.
- Selection features can only impose requirements on the SYNSEM value of a sign; they have no access to the word/phrase distinction.

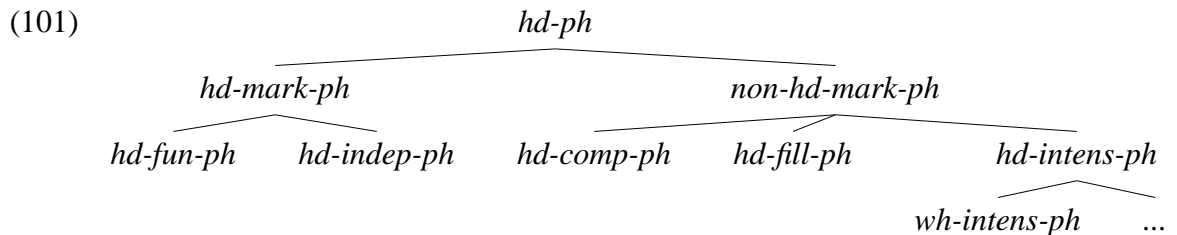

$$(102) \left[\begin{array}{l} wh-intens-ph \\ \text{HEAD-DTR} \left[\begin{array}{l} word \\ SS | LOC \left[\begin{array}{l} CAT | MARKING | WH \ pos \\ CONTENT \ parameter \end{array} \right] \end{array} \right] \\ \text{INTF-DTR} \left[\begin{array}{l} phrase \\ SS | BACKGROUND \left\{ \textit{emotional}(\underline{\text{I}}) \right\} \end{array} \right] \\ \text{CONTEXT} | \text{C-INDICES} | \text{SPEAKER} \ \underline{\text{I}} \end{array} \right]$$

- The head daughter is a word.
- The head daughter is extracted (as opposed to in-situ).
- The head daughter denotes an object of type *parameter* (as opposed to *unusual-rel*).
- The intensifier is a phrase.
- The intensifier signals an emotion of the speaker (impatience, irritation, ...).

Another subtype of *hd-intens-ph* is the demonstrative phrase in *on this very day*.

7 Conclusion

The GS-2000 treatment of pied piping is

- nonlocal
- head-driven
- nearly exclusively lexicalist (exception: coordination)

The proposed alternative is

- local
- functor-driven
- partly lexicalist, partly construction-based

The advantages of the local functor-driven treatment:

- all constraints are expressed in unadorned TFS formalism
- no separate constraints for the propagation of WH values
- no need for nonbranching phrase structure rules
- an accurate treatment of pied piping in PPs
- a more plausible structure for predeterminers
- a more plausible treatment of *wh*-intensifiers

References

- Allegranza, V. (1998). Determiners as functors: NP structure in Italian, in S. Balari and L. Dini (eds), *Romance in HPSG*, CSLI Publications, Stanford, pp. 55–107.
- Ginzburg, J. and Sag, I. (2000). *Interrogative Investigations*, CSLI Publications, Stanford.
- Holler-Feldhaus, A. (2001). An HPSG analysis of German wh-interrogatives, in W. Meurers and T. Kiss (eds), *Constraint-based approaches to Germanic syntax*, CSLI Publications, Stanford, pp. 77–109.
- Hukari, T. and Levine, R. (1996). Phrase structure grammar: the next generation, *Journal of Linguistics* **32**: 465–496.
- Pollard, C. and Sag, I. (1994). *Head-driven Phrase Structure Grammar*, CSLI Publications and University of Chicago Press, Stanford/Chicago.
- Quirk, R., Greenbaum, S., Leech, G. and Svartvik, J. (1985). *A comprehensive grammar of the English language*, Longman, London and New York.
- Soehn, P. and Sailer, M. (2003). At first blush on tenterhooks: About selectional restrictions imposed by nonheads, in G. Jaeger, P. Monachesi, G. Penn and S. Wintner (eds), *Proceedings of the Formal Grammar conference 2003.*, pp. 149–161.
- Van Eynde, F. (1998). The immediate dominance schemata of HPSG, in P.-A. Coppen, H. van Halteren and L. Teunissen (eds), *Computational Linguistics in the Netherlands 1997*, Rodopi, Amsterdam/Atlanta, pp. 119–133.
- Van Eynde, F. (2004). Pied piping is a local dependency, in S. Müller (ed.), *Proceedings of HPSG04 Conference*, CSLI Publications, Stanford University, pp. 313–334.
- Van Eynde, F. (2005). A head-driven treatment of asymmetric coordination and apposition, in S. Müller (ed.), *Proceedings of HPSG05 Conference*, CSLI Publications, Stanford University, pp. 313–334.
- Van Riemsdijk, H. (1994). Another note on clausal pied-piping, in G. Cinque, J. Koster, J.-Y. Pollock, L. Rizzi and R. Zanuttini (eds), *Paths towards universal grammar*, Georgetown University Press, Washington, D.C., pp. 331–342.