

# Sign Language Generation in an ALE HPSG

Ian Marshall, Éva Sáfár

School of Information Systems

University of East Anglia

Norwich, NR4 7TJ, UK

im@sys.uea.ac.uk, es@sys.uea.ac.uk

## 1 Abstract

During the past fifty years sign languages have been recognised as genuine languages with their own syntax and distinctive phonology. In the case of sign languages, phonetic description characterises the manual and non-manual aspects of signing. The latter relate to facial expression and upper torso position. In the case of manual components these characterise hand shape, orientation and position, and hand/arm movement in three dimensional space around the signer's body. These phonetic characterisations can be notated as HamNoSys descriptions of signs which has an executable interpretation to drive an avatar.

The HPSG sign language generation component of a text to sign language system prototype is described. The assimilation of SL morphological features to generate signs which respect positional agreement in signing space are emphasised.

## 2 Introduction

A prototype English text to sign language (SL) translation system has been developed<sup>1</sup>. English text is analysed into a Discourse Representation Structure Representation (DRS). The DRS is transformed into HPSG sem components as input to an ALE based SL generation component for British Sign Language (BSL) The Hamburg Notation System (HamNoSys)(Prillwitz et al., 1989; Hanke and Schmaling, 2001; Hanke, 2002) provides the SL phonetic description which is subsequently input to a 'virtual human' avatar (Figure 1)<sup>2</sup>(Kennaway, 2001).

A constraint based lexicalist framework of HPSG (Pollard and Sag, 1994; Ginzburg and Sag, 2000) is appropriate as sign order in SLs is largely lexically deter-

<sup>1</sup>This work was initiated within *ViSiCAST*, an EU Framework V supported project which builds on work supported by the UK Independent Television Commission and Post Office. The project develops virtual signing technology in order to provide information access and services to Deaf people.

<sup>2</sup>The avatar illustrated was developed by Televirtual, Norwich within *ViSiCAST*.

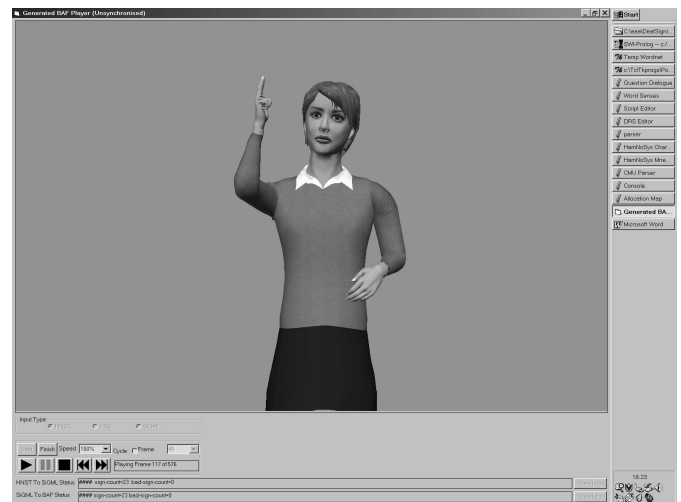

Figure 1: Avatar sign realisation

mined: verbs and adjectives typically determine whether their complements precede or succeed them. In addition the uniform representation of phonetic, syntactic and semantic information facilitates constraining of a complex though determinate information flow between lexical items and sign space representation for determining morphological constituents.

## 3 A Brief Characterisation of Sign Language Phenomena

This discussion concentrates upon the use of HPSG for generation of the manual components of signing in British Sign Language (BSL). In particular, we note the following phenomena (Brien, 1992; Sutton-Spence and Woll, 1999)

1. some nominals can be signed at specific positions in signing space and these locations then have syntactic significance
2. nominals which cannot be located in this way can be positioned in signing space by indexing a particular location

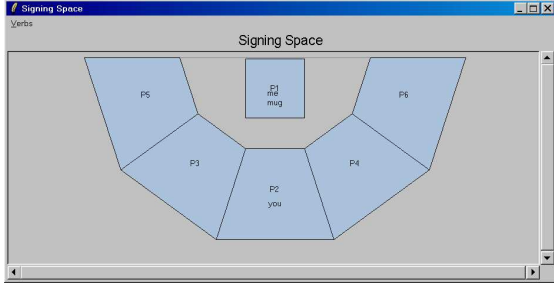

Figure 2: Signing Space Positions

after the sign

3. nominals can be referred to anaphorically by inclusion of classifier handshapes within manipulator verbs
4. directional verbs must be syntactically consistent with the locations of their subject and object
5. verbs exhibits syntactic agreement for number with their arguments.

In addition, particular positions in signing space (see Figure 2) can be populated by more than one object or person though typically these can be distinguished by different classifier handshapes. The sentence *I take the mug* is glossed as

MUG(px) TAKE(px,p1,manip\_handshape(MUG)) {I(p1)}

where the original position of the mug and I must agree with the start and end positions of the sign for TAKE. The fully instantiated generated HamNoSys phonetic form for this sentence is:

```
[ [ mug ],
  [ non_raised ],
  [ hamfist, hamthumbacrossmod, hamextfingerol,
    hampalml, hamshoulders, hamclose, hamparbegin,
    hammoveu, hamarcu, hamsmallmod, hamreplace,
    hamextfingerul, hampalmdl, hamparend ] ],
[ [ take ],
  [ non_raised ],
  [ hamceeall, hamextfingeror, hambetween,
    hamextfingerr, hampalml, hamshoulders, hamlrat,
    hamarmextended, hamreplace, hamextfingeror,
    hambetween, hamextfingerr, hampalml, hamchest,
    hamclose ] ],
[ [ me ],
  [ non_raised ],
  [ hamfinger2, hamthumbacrossmod, hamextfingeril,
    hampalmr, hamchest, hamtouch ] ]
```

## 4 The Feature Structure

The HPSG feature structure was designed for parallel development of lexicons for a number of different national sign languages<sup>3</sup>. To account for the SL phenomena above SL constituents are subclassified as *sentence*, *sent*, *phrase*, *word* and *leer* (German 'empty' denoting

<sup>3</sup>Colleagues at the University of Hamburg designed the initial structure, subsequently revised to accommodate a number of refinements as work progressed.

dropped items). *Word* is the feature structure for an individual sign, and is subclassified as *verb*, *noun* and *adjective*. *Verb* is subclassified to distinguish *fixed*, *directional* (parameterised by start/end positions), *manipulative* (parameterised by a proform classifier handshape). Combinations of these types are permitted, for example 'take' is a *dir(ectional)manip(ulative)* verb. *Adj* is subclassified to indicate whether an adjective requires pre or post complements. *Noun* is subclassified as *person*, *object* or *location*, each of the former two may be either invariant or locatable in signing space. Each constituent has a relatively standard division of SEM, SYN and PHON features, and in addition a (English textual) GLOSS.

The most significant deviations from more standard HPSG grammars are the complexity of the phonetic component and the use of a CONTEXT feature within SYN.

## 5 The Lexicon and Grammar Rules

[[take], [Brow], [telk, Nhd, Hsh, Efd, Plm, Const, Heightobj, Distobj, R1, hamreplace, Efd, Plm, Heightsubj, Distsubj, R2]] ==>

```
[ word
  gloss take
  phon see Fig 4
  syn see Fig 5
  sem see Fig 6 ]
```

Figure 3: take's LHS

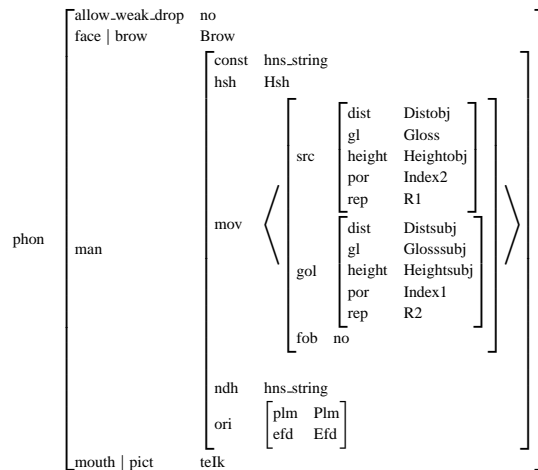

Figure 4: take's Phon

Figures 3, 4, 5 and 6 illustrates a typical lexical entry for 'take'. The lexicon exhibits the most significant adaptation of ALE to accommodate the BSL grammar. The standard ALE implementation calls the predicate 'gen' which, for a successful derivation, returns a sequence of words in one of its arguments. The ALE implementation has been modified so that this result is a list of

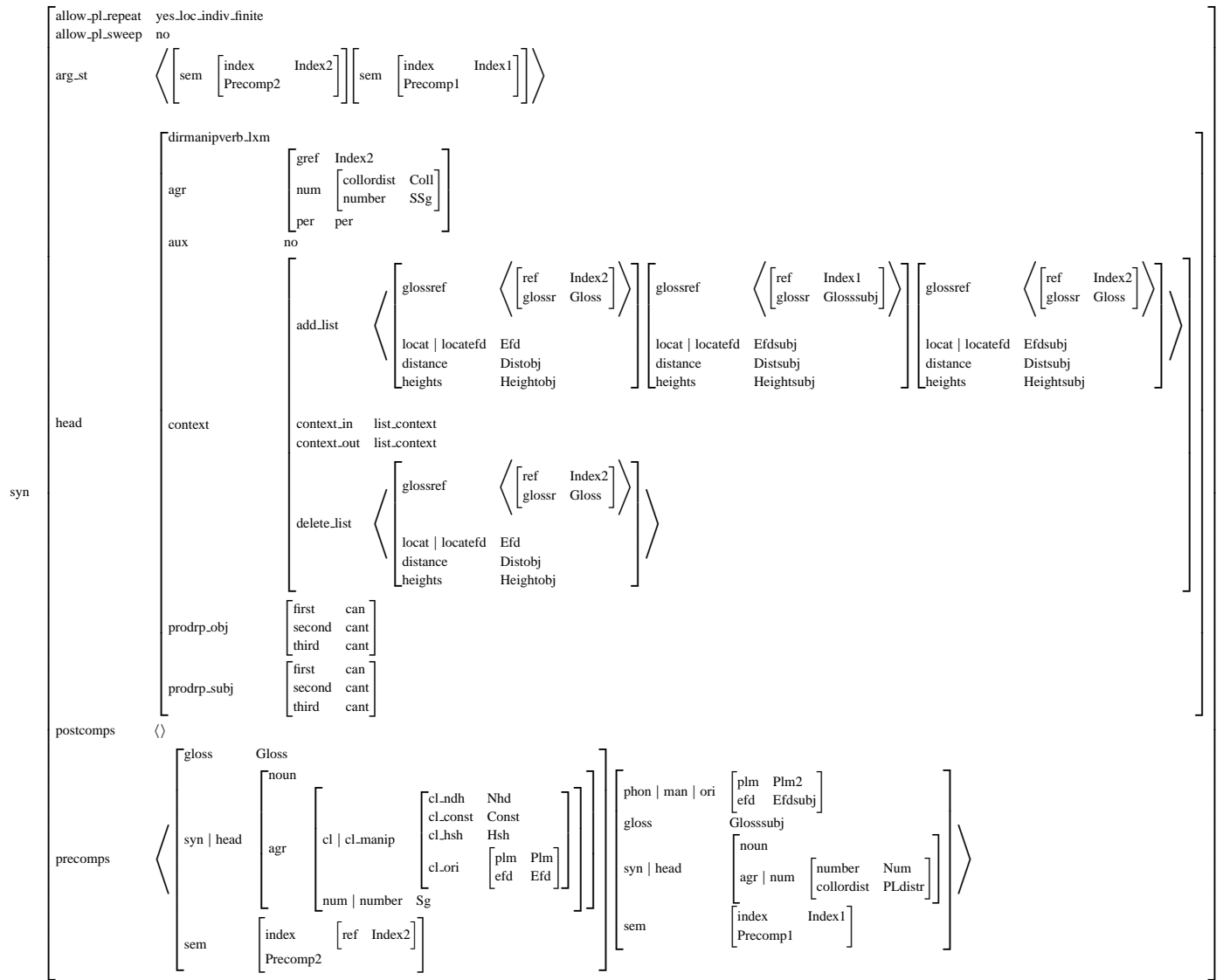

Figure 5: take's Syn

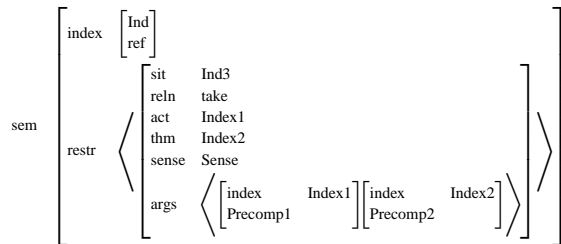

Figure 6: take's Sem

sign phonetic descriptions, each element of which is a 3 tuple of sign gloss, non-manual and manual descriptions. The latter two are themselves lists of HamNoSys

sign 'phonemes'. Thus, the structuring of the PHON feature duplicates information collated in the LHS of lexical items. The flattened phonetical non-manual and manual lists are determined locally by the lexical item (rather than by a post generation tree walk). However, as variables in the LHS of lexical items cannot be referenced non-locally in grammar rules, the PHON feature functions as a 'scratch area' via which non-local bindings and constraints are established.

The SYN component contains features which determine sentence mode, pluralisation, (pro)noun drop and placement (anaphoric reference in signing space). In addition the usual interpretations of pre- and post-complements governs grammar rule selection and thus determines aspects of sign order.

last\_complement\_pron\_rule

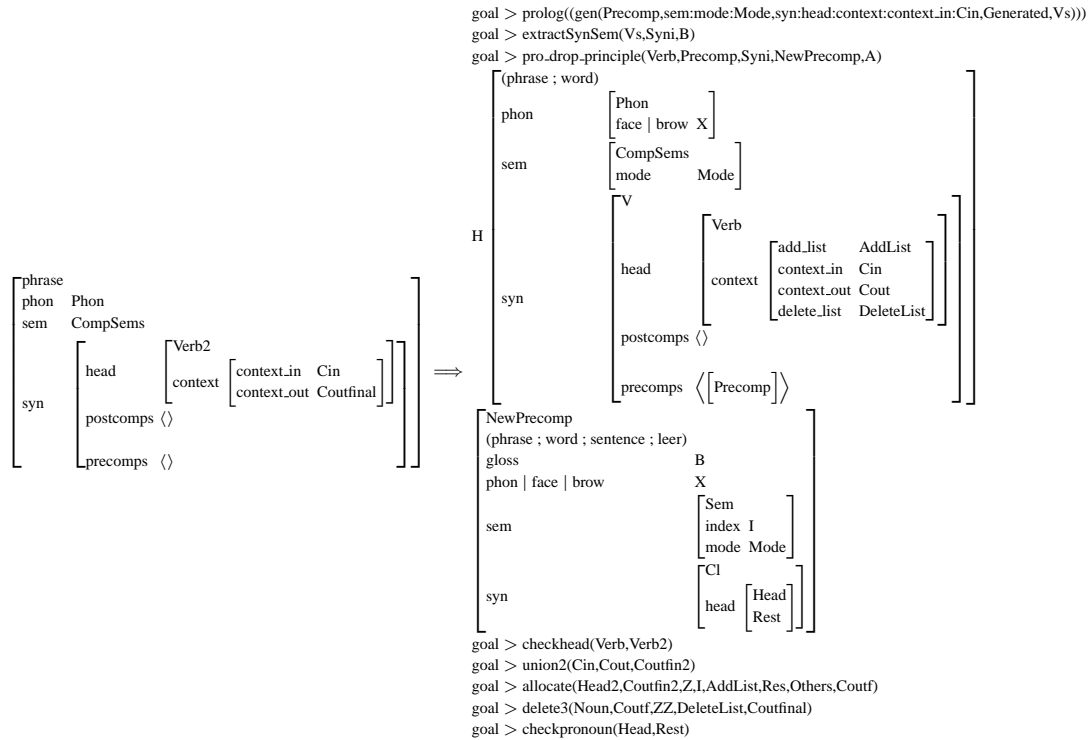

Figure 7: Last Complement Pronoun Rule

Sentence MODE is propagated throughout a HPSG structure for a sentence by associating sentence type (declarative, yes-no question, wh-question) with eye BROW position (normal, raised, furrowed) in PHON and propagating this throughout all mother, head daughter (sem\_head) and daughter (cat) nodes in both chain and non-chain rules. Currently this is overly simplistic as eye brow position is significant at the ends of questions (rather than throughout the entire proposition).

Anaphoric relationships are achieved by reference to positions within signing space. Nominals can be located at specific positions (either by being signed at that location if they are not fixed signs or by pointing). Subsequently, these positions can be used to refer to the nominal. In the case of directional verbs, such positions are obligatory morphemes of the sign and must agree with the appropriate position of the sign. Such agreement is achieved by propagating a map of sign space positions (phonemes for pointing, moving towards and moving to each location) through derivation in the SYN:HEAD:CONTEXT feature. CONTEXT\_IN is the current state of signing space which at the start of the derivation indicates positions of 'I' and 'you' and other non-allocated available positions. Nominals which are referred to anaphorically and those which are arguments of directional verbs of movement have to be registered

within signing space. This is achieved by associating planning system style ADD\_LIST and DELETE\_LIST features with directional verbs. The ADD\_LIST is an ordered sequence of registrations which are instantiated to indexical information associated with its nominal arguments and are used to register the start and end positions. The DELETE\_LIST is used with directional verbs of movement in order to model movement of an object or person to the destination location. The CONTEXT\_OUT feature records the result of such registrations in order that an up-to-date model of signing space is propagated through a derivation.

The values Hsh, Const, Plm and Efd in the LHS of the rule (Figure 3) which determine the handshape are propagated from the classifier features associated with PreComp2 in SYN:PRECOMPS (Figure 5). Precomp2 is instantiated to the feature structure of the nominal, and hence its classifier proforms.

ALE's head-driven generation algorithm (Carpenter and Penn, 1999) is appropriate as the modelled BSL constructions are analysed as consisting of an identifiable head-daughter. A nested SEM structure is derived from the DRS representation coupled with an initial allocation map for SYN:HEAD:CONTEXT:CONTEXT\_IN. The semantics predicate propagates both the SEM and CONTEXT\_IN component of SYN when non-chain rules

### Allocation Map Propagation Rule

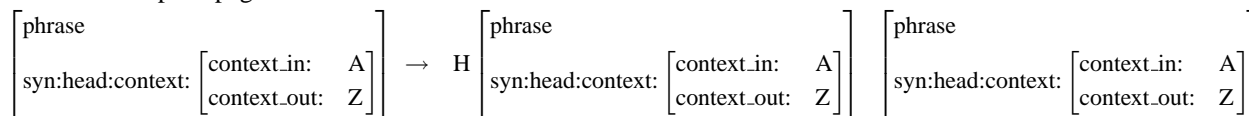

Figure 8: Rule 1 : Default Propagation

### Allocation Map Propagation Rule

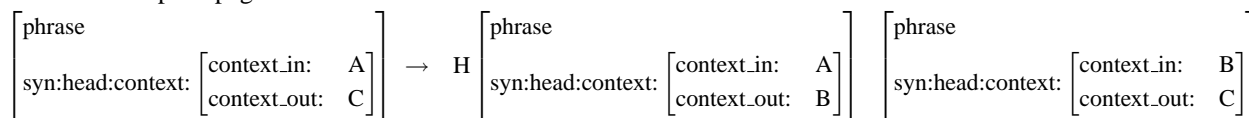

Figure 9: Rule 2: Last Complement Directional Verb Propagation

are used. Bottom-up chain rules have a conventional form as illustrated in Figure 7.

The CONTEXT\_IN feature contains the available allocation map positions and reflects the state of occupied and free positions at a given stage of generation. The following illustrates a single position using HamNoSys mnemonics for the gloss YOU.

```
syn:head:context:context_in:
  [(glossref:[(glossr:you,ref:Ind1)],
   halfway_mov:[hammoveo],
   locat:(locatplm:[hampalml],
           locatefd:[hamextfingero]),
   distance:[hamarmextended],
   heights:[hamchest]),
   ...]
```

The movement of the sign towards this position is an outward movement from the body (hammoveo), the orientation of the palm is to the left (hampalml), extended finger direction is outward (hamextfingero). The position of the finger relative to the body is chest level (hamchest) at an extended arm distance (hamarmextended).

The propagation of CONTEXT\_IN and CONTEXT\_OUT are governed by two rules (Figures 8 and 9). Rule 1 permits nominals to be associated with already allocated positions or vacant positions in signing space. This default propagation also allows these allocations to be inherited by non-final complement rules. Rule 2 allows final complement rules for directional verbs involving movement to re-associate re-located objects and persons with updated positions in signing space.

The ordering of head-daughter followed by daughter supports proposition-final subject pronouns. Procedural attachment of the pro\_drop\_principle allows such a pronoun to be optionally deleted due to 'take's PRO-DRP\_SUBJ:FIRST feature. Such deletion requires that the non-head daughter is derived as an explicit pronoun (recorded in Syn) modified (as Syni) to generate its pronominal features even though its LHS lexical realisation is empty (see Figure 7). If two ALE cat>

daughters are generated to achieve this then both lexical LHSs would appear in the resulting sign sequence. Hence derivation of the pronominal form is achieved by a recursive call to ALE ('gen').

## 6 Conclusions

We invite comment on the association of CONTEXT\_OUT with the HEAD feature thereby undermining the Head Feature Principle by so doing.

In passing we propose a comparison with the following English sentences:

1. I held the foot of the ladder as John passed the book down/?up to me.
2. ?Leslie went to London where he had a sex change operation but now she has returned to Newcastle.

## References

- D. (Ed.) Brien. 1992. *Dictionary of British Sign Language/English*. Faber and Faber, London, Boston.
- B. Carpenter and G. Penn. 1999. *The Attribute Logic Engine. User's Guide. Version 3.2 Beta*. Bell Labs.
- J. Ginzburg and I.A. Sag. 2000. *Interrogative Investigations - The Form, Meaning, and Use of English Interrogatives*. CSLI Publications, Stanford, California.
- T. Hanke and C. Schmalting. 2001. A hamnosys-based phonetic transcription system as a basis for sign language generation. In *Gesture Workshop 2001*, London.
- T. Hanke. 2002. Hamnosys in a sign language generation context. In R. Schulmeister and H. Reinitzer, editors, *Progress in sign language research, (In honor of Siegmund Prillwitz)*, International Studies on Sign Language and Communication of the Deaf; 40, pages pp. 249–264, Hamburg.
- J.R. Kennaway. 2001. Synthetic animation of deaf signing gestures. In *The Fourth International Workshop on Gesture and Sign Language Interaction, Gesture Workshop 2001 (GW2001)*, City University, London, UK.
- C. Pollard and I.A. Sag. 1994. *Head-Driven Phrase Structure Grammar*. The University of Chicago Press, Chicago.
- S. Prillwitz, R. Leven, H. Zienert, T. Hanke, J. Henning, et al. 1989. *Hamburg Notation System for Sign Languages - An Introductory Guide*. International Studies on Sign Language and the Communication of the Deaf, Volume 5., Institute of German Sign Language and Communication of the Deaf, University of Hamburg.
- R. Sutton-Spence and B. Woll. 1999. *The Linguistics of British Sign Language. An Introduction*. University Press, Cambridge.